

Tender Notice

National Small Industries Corporation Limited
NSIC Bhawan
Okhla Industrial Estate
New Delhi-110020
Tel: +91-11-26826941/26826847
Email: tech@nsic.co.in

Tender no. : SIC/HO/TID/AU/12-168 Date: 20th June, 2016

Subject: Supply of one set of standard mould for plastic goods (lunch box, plate and bowl) for Injection Moulding Machine.

NSIC is setting up India-Africa Incubation Centre for Small Enterprise Establishment at Banjul (Gambia).

We are please to invite your offer in two parts viz. (a) Technical and (b) Financial, strictly as per enclosed terms and conditions and instructions to bidders, in sealed covers for the under mentioned plant and machinery / equipment required for supply and installation at Banjul (Gambia) consisting of the following:

Sl. No.	Description	Quantity
1.	Set of standard moulds for manufacturing plastic lunch box on Electronica Make Injection Moulding Machine, Model: Optima - 75 (Distance between tie bars – 350 mm x 310 mm) No. of cavity – one Mould thickness – 125 mm (min.), 310(max.) Details as per attached sketch	One set
2.	Set of standard moulds for manufacturing plastic lunch plate on Electronica Make Injection Moulding Machine, Model: Optima - 75 No. of cavity – one Mould thickness – 125 mm (min.), 310(max.) Details as per attached sketch	One set
3.	Set of standard moulds for manufacturing plastic Bowl on Electronica Make Injection Moulding Machine, Model: Optima - 75	One set

	No. of cavity – one Mould thickness – 125 mm (min.), 310(max.) Details as per attached sketch	
4.	Tool set for standard mould operation.	One set

The detailed tender document can be obtained free of cost from Chief Manager (TID) at the above address. The tender document can also be downloaded from NSIC website www.nsic.co.in. Any clarification on technical specifications can be obtained in writing from NSIC before tender opening. Manufacturers are welcome to have pre-bid meeting with NSIC for better understanding our requirements.

Please submit your lowest quotation / offer for the above requirement subject to our terms and conditions. Your offer should be submitted to General Manager (TID), National Small Industries Corporation Limited, NSIC Bhawan, Okhla Industrial Estate, New Delhi-110020 latest by 5th July, 2016 till 5:00 P.M. Offers received after the last date and scheduled time shall not be considered.

The format for technical bid and financial bid shall be as per Annexure-I and Annexure-II respectively. The offer should be submitted with a covering letter as per format at Annexure-III in a **sealed envelope clearly mentioning the above tender number on top of the envelope.**

The technical bid shall be opened on 6th July, 2016 at 2:30 P.M. in the presence of authorized representatives of the bidders who may like to be present. The authorized representative should bring authority letter from their principals for attending the bid opening.

Note: The vendor should submit their best price while submitting their bids itself and they will not be allowed to revise the price any time thereafter.

NSIC reserves the right to reject one or all of the bids without assigning any reasons.

KINDLY READ ALL TERMS AND CONDITIONS OF "TENDER DOCUMENT" THOROUGHLY. QUOTATION NOT IN ACCORDANCE WITH THE TERMS AND CONDITIONS IS LIABLE TO BE DISQUALIFIED AND IGNORED.

General Manager (TID)

Important Instructions to bidders for submission of tender

1) Preparation of Bids:

The bids should be prepared in the following manner: -

- a. The Bid shall be neatly arranged, plain and intelligible.
- b. Each page of the bid should be signed by the authorised person. Letter regarding the authorisation of such person should be obtained from the Principal / Manufacturer and enclosed with the bid.
- c. Insertions, postscripts, additions and alterations shall not be recognized, unless confirmed by bidder's signature.
- d. Bids should not contain any terms and conditions, printed or otherwise, which are not applicable to the Bid.
- e. Any conditional bid not adhering to the terms & conditions of the tender or part bid shall be rejected.
- f. The bidder should be the Principal / Original manufacturers of plant & machinery/ equipment, failing which the quotation shall not be considered.
- g. The bidders should have executed at least three purchase orders / contracts of equivalent value in the last five years. The bidder is required to submit catalogue of the plant & machinery/ equipment, complete reference of the past supply of equipment for the same or similar specification giving details of customer with name of the contact person, Fax no, phone no, E-mail.
- h. The bidders (originals manufacturers) will have to submit ink-signed offer / bid in original to NSIC. **Bids not complying with this condition shall not be considered.**
- i. In the Financial Bid, prices are to be indicated in both figures and words. In case of any discrepancy of value the prices quoted in words shall be considered for evaluation and establishing L1 status.
- j. No price variation clause will be entertained.
- k. Specifications are the basic essence of the "Product". Mere copying of the tender specifications by the Bidder into their bids shall not make them eligible for consideration.

Signature of Bidder
Seal of Bidder

Appropriate and sufficient evidence of conformity by way of data (catalogues etc.) shall be furnished. There should be an item-by-item commentary on the Specifications demonstrating responsiveness of the offered equipment to the specifications.

- I. Bid with any pre-conditions (like conditional discounts) for price are liable to be "Not considered/Rejected".

2) **Submission of Bids:**

- a. Bids must be received by NSIC on or before the due date and time at the address specified in the tender document. In the event of the specified date for the submission of bids being declared a holiday for NSIC, the bid-closing deadline will stand extended to the next working day up to the same time.
- b. Any bid received by NSIC after the deadline for submission of bids, will not be accepted and returned unopened to the bidder.
- c. NSIC at its discretion may extend the deadline for the submission of bids if the bid document undergoes changes during the bidding period, in order to give prospective bidders time to take into consideration the amendments while preparing their bids.
- d. In case of receipt of inadequate numbers of bids, NSIC may extend the deadline for submission of bids giving opportunity to other bidders to participate in the bidding process to make it competitive.
- e. If the Supplier submits only one envelop / cover containing all the bids or combined bids e.g. techno-commercial bid & price bid together, the bid is liable for rejection.

NOTE: The manufacturers should submit their best price at this stage itself and they will not be allowed to revise the price. Any revision / discount given by manufacturers subsequently will be ignored.

3) **Amendment of Bidding Documents:**

- a. At any time prior to the deadline for submission of bids, NSIC may, for any reason, whether on its own initiative or

Signature of Bidder
Seal of Bidder

in response to the clarification request by a prospective bidder, modify the bid document.

- b. All prospective bidders who have requested for the bidding document will be notified of the amendment in writing, and such amendments/ modifications will be binding on them.

4) Bid opening and evaluation of Bids:

- a. The technical bids shall be opened on 6th July, 2016 at 2:30 P.M.
- b. Bidder whose technical bid is qualified based on the eligibility criteria as specified in this tender document will be considered for financial bid evaluation. The date and time of opening of the financial bid will be informed to such bidders.
- c. NSIC will open financial bids of only the technically qualified, in the presence of the bidders or their authorised representative who choose to attend the bid opening.
- d. The bidder's authorised representative who attends the bid opening shall sign an attendance register as a proof of having attended the bid opening.
- e. The bidder's name, bid prices, discounts and such other details will be announced at the time of opening of the financial bids.

5) Award of Contract

- a. The financial bids of the technically qualified bidders shall be opened by the constituted committee. Thereafter the committee shall prepare the comparative statement (CST) based on the FOR, ICD, Tughlakabad, New Delhi price quoted by the bidders. This will facilitate to shortlist the L-1 bidder quoting the lowest price.
- b. L-1 will be decided on the basis of total value of the bid.
- c. NSIC shall award the contract to the eligible bidder whose financial bid has been accepted and determined as the lowest evaluated financial bid.

Signature of Bidder
Seal of Bidder

- d. If more than one bidder happens to quote the same lowest price, NSIC reserves the right to award the contract to any one bidder.
- e. Supply order shall be placed for supply and installation of machinery and equipment required at Banjul. The bidder shall deposit 'Security Deposit' for ₹20,000/- (Rupees Twenty thousand only) for supply orders placed.
- f. The successful bidder, on award of contract/order, must send the contract/order acceptance in writing, within 7 days of award of contract/order, failing which the EMD will be forfeited.

6) Interpretation of the clauses in the Tender Document / Contract Document

In case of any ambiguity / dispute in the interpretation of any of the clauses in this Tender Document, NSIC's interpretation of the clauses shall be final and binding on all parties.

7) Earnest Money Deposit:

- a. The units registered with Central Purchase Organization (DGS&D), National Small Industries Corporation (NSIC) or the concerned Ministry or Department shall be exempted from the payment of Earnest Money as defined under Rule 157 of General Financial Rules (GFR), 2005.

In such case, copy of the certificate showing registration with the above mentioned institutions to be enclosed alongwith the Technical Bid.

- b. In case, the unit is not covered under a. above, it should submit the offer along with Earnest Money Deposit (EMD) for ₹20,000/- (in words Rupees Twenty thousand only) by way of Demand Draft (DD) drawn in favour of "National Small Industries Corporation Limited" payable at New Delhi for one set of goods only (even in case the bidder is quoting for more than one set). No cash / cheque towards EMD shall be accepted. The DD for EMD should be placed inside the envelope containing technical bid. The offers without EMD shall be rejected.
- c. The EMD of unsuccessful bidder shall be refunded within 30 days from the award of contract.

Signature of Bidder
Seal of Bidder

- d. No interest will be allowed for earnest money deposited with the Company.
- e. The EMD shall be forfeited:
 - 1. If the bidder withdraws the bid during the period of bid validity specified in the tender.
 - 2. If the successful bidder fails to furnish the acceptance in writing, within 7 days of award of contract/order.

8) **Security Deposit**

- a. The EMD of successful bidder shall be kept as 'Security Deposit' for supply of goods against each supply order and shall be released at the time of final payment after successful completion of work.
- b. In case of bidder exempted from payment of EMD (as mentioned in Para 7 a. above), 'Security Deposit' for ₹20,000/- by way of demand draft in favour of "National Small Industries Corporation Limited" payable at New Delhi should be submitted alongwith order acceptance against each supply order. However, the successful bidder can furnish a Bank Guarantee of Nationalized Bank of equivalent amount in lieu of 'Security Deposit' valid for one year from the date of supply order.

9) **Prices:**

All items are to be quoted in INR only in the format as per Annexure-II. The price quoted should be inclusive of sea worthy packing, insurance and freight on FOR, ICD, Tughlakabad, New Delhi basis. **The prices should also be inclusive of all taxes and duties as applicable.** The price quoted shall be considered firm and no price escalation shall be permitted.

10) **Validity of the Quote:**

The validity of quote should be at least six months (180 days) from the closing date of tender. A bid valid for a shorter period shall stand rejected.

NSIC may ask for the bidder's consent to extend the period of validity. Such request and the response shall be made in writing only. A bidder agreeing to the request for extension will not be permitted to modify his bid.

Signature of Bidder
Seal of Bidder

11) Delivery period:

The goods shall be delivered to NSIC's C&F agent at Delhi (or any other place as specified by NSIC) within 60 days from the date of award of contract. Part delivery shall not be permitted. Separate dispatch instruction shall be issued after inspection of goods and acceptance thereof by NSIC. No other delivery terms shall be acceptable.

12) Taxes / Duties:

- a. The bidders should be registered with sales tax / income tax department of Govt. of India and should hold a valid VAT registration certificate, as applicable.
- b. Sales tax, excise duty, VAT, octroi or any other tax shall be paid on actual as per rule applicable and on production of documentary proof. **No tax concession form or proof of shipment of goods shall be issued.**

13) Payment terms:

- a. 80% of order value to be released on submission of following documents:
 - i. Signed commercial Invoice-two copies certifying that the goods are exactly as per the purchase order and the specification quoted.
 - ii. One copy of NSIC supply order.
 - iii. Proof of delivery of the consignment to our C&F agent.
 - iv. Clean report of findings issued by NSIC.
 - v. Packing list two copies duly signed.
- b. Balance 20% order value shall be released after successful installation and commissioning of equipment at site and upon furnishing performance guarantee as stated at para 15 of this tender document.

14) Packing & Marking:

Consignment must be packed in Sea Worthy in strong packing cases, taking all precaution against damage during handling and sea weather corrosion.

Signature of Bidder
Seal of Bidder

Proper marking on the packing cases should be made for smooth handling of consignment. The supplier will be held responsible for the plant and machinery / equipments not being sufficiently and properly packed and in such eventuality the supplier shall have to transport them by rail, road at their destination, at his expense free from loss or damage.

Every package delivered under our order shall at the expense of the supplier be distinctly marked with description and quantity or contents with the consignee name and address (which shall be notified subsequently) with gross weight and net weight, with the distinctive number and mark which is also to be shown for the purpose of identification on the suppliers packing account.

Each packet shall contain a packing note quoting a number and date of our order and showing its contents in detail.

15) Performance Guarantee:

Performance Guarantee in the form of Bank Guarantee (BG) on the prescribed format @10% of order value in favour of NSIC Ltd. towards performance of the contract (Purchase Order) shall be required to be submitted by the party after successful installation of the project at site. This bank guarantee shall be valid for 18 months from date of shipment or 12 months from the date of successful completion of installation and commissioning at site whichever is later.

16) Pre-Shipment Inspection:

The plant and machinery / equipment to be supplied and packing thereof shall be subject to inspection by NSIC or third party (name shall be conveyed to the successful bidder) at manufacturer's premises prior to dispatch thereof. Approval and clean report of findings shall be submitted at the time of claiming 80% payment. Machinery & equipment including packing boxes shall be offered by the awarded unit for inspection at least 10 days before the stipulated date of delivery. Deviations, if any pointed out by the visiting inspection team, as mentioned above, shall be corrected and the machinery and equipment as per specification shall be dispatched on or before the contract delivery date.

17) Liquidated damages:

In the event of delay in supply of the goods within the stipulated period, Liquidated Damages (LD) shall be charged by NSIC @

Signature of Bidder
Seal of Bidder

½% (one-half of one percent) of the total order value per week of delay or part thereof subject to a maximum of 5 (five percent) of the order value. Supplier shall deduct the applicable LD from the first payment while raising the claim for the same.

18) Insurance:

All goods are to be insured for 110% of the FOR value of the goods by successful bidder from the works to warehouse of our C&F agent at Delhi.

19) Installation & Commissioning:

- a. The awarded bidders shall have to depute expert(s) for installation & commissioning at site as and when instructed by NSIC.
- b. No additional charges shall be payable for installation & commissioning of equipment at site except for the following:
 - i. Return economy class Air Ticket shall be provided by NSIC.
 - ii. Lodging shall be taken care of by NSIC.
 - iii. Local conveyance shall be taken care of by NSIC.
 - iv. Out of pocket allowance as per MEA rate shall be paid by NSIC.
 - v. Skilled and unskilled workers shall be provided by Host country at site.
 - vi. The supplier has to inform in advance about the material handling facilities to be arranged by host country for successful installation, commissioning, training and pilot production from the machines and equipment supplied.
- c. Time and manpower required (skilled / unskilled) for Erection & commissioning should be clearly given in terms of working days and number respectively.
- d. The supplier will be required to train for at least 7 days the operators as decided by NSIC / host country.

20) After Sales Service / Warranties by Suppliers:

The equipment shall be warranted for any manufacturing defect for a period of 18 months from the date of shipment or 12 months from the date of successful completion of installation and commissioning at site, whichever is later. Should any part or parts fail or proved defective within the period specified above, owing to defect in design, material or workmanship, the

Signature of Bidder
Seal of Bidder

supplier will have to replace them at the place of installation free of all charges.

During the warranty period, expert(s) shall be deputed at site by the awarded unit whenever found essential and which cannot be undertaken locally or by the NSIC's experts including rectifying any defect / malfunctioning of plant & machinery. The cost of deputation of expert(s) and any other associated expenditure shall be borne by the awarded unit.

21) Technical Documents:

The awarded unit shall provide technical documents like operation and maintenance manual etc. in English language in three copies for each items of equipment. Two copies to go with the consignment, one copy to be forwarded to NSIC office.

22) Risk Purchase:

In case of delays in supplies / defective supplies or non-fulfillment of any other terms and conditions given in the Supply Order, NSIC may cancel the supply order in full or part thereof, and may also make the purchase of such material from elsewhere / alternative source at the risk and cost of the supplier.

In case vendor does not agree to above risk purchase clause, their offer is liable to be rejected. In case any vendor accepts risk purchase clause initially and subsequently declines to honour the term in the eventuality of RISK PURCHASE, they may be banned for business with NSIC.

23) Cancellation of Bids

- a. NSIC reserves the rights to cancel any bid without assigning any reasons.
- b. NSIC reserves the rights to cancel bids and refloat a fresh tender, at any time after opening of the bids, in case it finds the response to its bid are not meeting its requirement. This shall be at the sole discretion of NSIC.

Signature of Bidder
Seal of Bidder

24) Blacklisting / Debarring of Firm

- a. Units blacklisted by any Government Departments / PSUs are not eligible to participate in the tender.
- b. If the unit(s) commits breach of contract, it shall be black listed / debarred for further business with NSIC for a declared period.

25) Post Tender Negotiations

- a. NSIC reserves the right to conduct negotiations on the 'Price' and 'other commercial terms' with the lowest ranked offerer, and
- b. If so required by NSIC, supplier may have to share their cost data / costing sheet with NSIC.

26) Force Majeure

If at any time during the currency of this contract, the performance in whole or in part, by either party of any obligations under this contract shall be prevented or delayed by reason, of any war, hostilities, acts of the public enemy, civil commotion, sabotage, fires, explosions, epidemics, quarantine, restrictions or acts of GOD (hereinafter referred to as events), then provided notice of happening of any such events is given by either party to other within ten days from the date of occurrence thereof, neither party shall reason of such events be entitled to terminate this contract nor shall either party have any such non performance and delay is resumed as soon as practicable after such events has come to an end or ceased to exist. If the performance in whole or part of any obligation under this contract is prevented or delayed by reason or any such event claims for extension of time shall be granted for period considered reasonable by the purchaser subject to prompt notification by the seller to the purchaser of the particulars of the events and supply to the purchaser if required of any supporting evidence. Any waiver of time in respect of partial installment shall not be deemed to be a waiver of time in respect of remaining deliveries.

Annexure-I

Signature of Bidder
Seal of Bidder

Format for technical bid

Sl. No.	Tender requirements	Quantity	Compliance (Yes/No)
	One set of standard mould for plastic goods (lunch box, plate and bowl as per the drawing and specs enclosed from Pg.20 to 23) for Injection Moulding Machine for Supply at Banjul (Gambia) consisting of the following:		
1.	Set of standard moulds for manufacturing plastic lunch box on Electronica Make Injection Moulding Machine, Model: Optima - 75 (Distance between tie bars – 350 mm x 310 mm) No. of cavity – one Mould thickness – 125 mm (min.), 310(max.) Details as per attached sketch	One set	
2.	Set of standard moulds for manufacturing plastic lunch plate on Electronica Make Injection Moulding Machine, Model: Optima - 75 No. of cavity – one Mould thickness – 125 mm (min.), 310(max.) Details as per attached sketch	One set	
3.	Set of standard moulds for manufacturing plastic Bowl on Electronica Make Injection Moulding Machine, Model: Optima - 75 No. of cavity – one Mould thickness – 125 mm (min.), 310(max.) Details as per attached sketch	One set	
4.	Tool set for standard mould operation such as: 1. Chain pulley – 1.0 ton – 1 No. 2. Silicon Mould Spray – 1 No. 3. Mould Spray – 8 Nos. 4. Mould Clamp – 8 Nos. 5. Mould Clamping Bolt – M16 x 100 – 8 Nos. 6. 'I' Bolt – 8 Nos. 7. Die Puller (for opening of Die) – 2 Nos. 8. Hammer – 2Kg – 1 No. 9. Hammer (Teflon) – 1 No. 10. ¼ BSP Cooling Nipples with clamps – 20 pcs 11. Diamond Needle file set – 1 Set (1 Dozen) 12. Oil Stone (4") – 4 Nos. 13. Emery Paper (fine polishing) – 8 Nos. 14. Needle File Set – 1 Set (1 Dozen)	One set	

Signature of Bidder
Seal of Bidder

	15. ¼" BSP Hand Taps – 1 Set 16. Hand Taps handle – 2 Nos. 17. High Speed Hand Grinding Machine with Collet, Collet Spanner and Mounting Wheels – 1 Set 18. Cooling pipe (suitable as per cooling nipple) – 10 mtr. 19. Oil Can (any other item required, please specify each item with specifications / quantity - use separate sheet)		
--	-------------------------------------------------------------------------------------------------------------------------------------------------------------------------------------------------------------------------------------------------------------------------------------------------------------------------------------------------------------------	--	--

Enclosure s:

1. Company profile with catalogues.
2. Detailed specification of all items mentioned above.
3. Copy of Client List/purchase orders/ contracts/Invoices/ of similar nature and size in the last five years.
4. Copy of Pan Card / Sales tax / VAT registration certificate.
5. Copy of SSI / MSME Memorandum part – II / NSIC registration certificate, if applicable.
6. Demand draft for Rs. 20,000/- as EMD.

Signature of Bidder
Seal of Bidder

Annexure-II**Financial price schedule**

Sl. No.	Description and Technical specification	Price (INR)	Tax & Duties (INR)	Total price (FOR, Delhi) (INR)
One set of standard mould for plastic goods (lunch box, plate and bowl as per the drawing and specs enclosed from Pg.20 to 23 below) for Injection Moulding Machine for Supply at Banjul (Gambia) consisting of the following:				
1.	Set of standard moulds for manufacturing plastic lunch box on Electronica Make Injection Moulding Machine, Model: Optima - 75 (Distance between tie bars – 350 mm x 310 mm) No. of cavity – one Mould thickness – 125 mm (min.), 310(max.) Details as per attached sketch	One set		
2.	Set of standard moulds for manufacturing plastic lunch plate on Electronica Make Injection Moulding Machine, Model: Optima - 75 No. of cavity – one Mould thickness – 125 mm (min.), 310(max.) Details as per attached sketch	One set		
3.	Set of standard moulds for manufacturing plastic Bowl on Electronica Make Injection Moulding Machine, Model: Optima - 75 No. of cavity – one Mould thickness – 125 mm (min.), 310(max.) Details as per attached sketch	One set		
4.	Tool set for mould operation such as: 1. Chain pulley – 1.0 ton – 1 No. 2. Silicon Mould Spray – 1 No. 3. Mould Spray – 8 Nos. 4. Mould Clamp – 8 Nos. 5. Mould Clamping Bolt – M16 x 100 – 8 Nos.	One set		

Signature of Bidder
Seal of Bidder

6. '1' Bolt – 8 Nos. 7. Die Puller (for opening of Die) – 2 Nos. 8. Hammer – 2Kg – 1 No. 9. Hammer (Teflon) – 1 No. 10. ¼ BSP Cooling Nipples with clamps – 20 pcs 11. Diamond Needle file set – 1 Set (1 Dozen) 12. Oil Stone (4") – 4 Nos. 13. Emery Paper (fine polishing) – 8 Nos. 14. Needle File Set – 1 Set (1 Dozen) 15. ¼" BSP Hand Taps – 1 Set 16. Hand Taps handle – 2 Nos. 17. High Speed Hand Grinding Machine with Collet, Collet Spanner and Mounting Wheels – 1 Set 18. Cooling pipe (suitable as per cooling nipple) – 10 mtr. 19. Oil Can ((any other item required, please specify each item with specifications / quantity - use separate sheet)).				
Total price FOR, ICD, Tuglakabad, New Delhi (Sl. No. 1 to 6)				

Lump sum price of one set of moulds (FOR, ICD, Tuglakabad, New Delhi : Rs. _____)

(in words Rupees: _____)

Note: The above price should be inclusive of sea-worthy packing, transportation, insurance, Taxes & Duties, Octroi, etc. **No tax concession form or proof of shipment of goods shall be issued.**

Signature of Bidder
Seal of Bidder

Annexure-IIIFormat of covering letter

Ref. No.:.....

Date:.....

General Manager (TID)
National Small Industries Corporation Limited
NSIC Bhawan,
Okhla Industrial Estate,
New Delhi-110020.

Ref.: Tender No SIC/HO/TID/AU/12-168 dated 20th June, 2015 for supply of one set of mould for plastic goods (lunch box, plate and bowl) for Injection Moulding Machine at Banjul (Gambia).

Dear Sir,

With reference to above tender notice, we are submitting herewith our offer for above as per following documents:

1. Technical bid in prescribed format as Annexure-I in sealed envelope no.1 along with enclosures (No financial figures should be mentioned directly or indirectly in technical bid).
2. EMD for ₹20,000/- in the form of Demand Draft in favour of "National Small Industries Corporation Limited" payable at New Delhi along with technical bid in an envelope marked "EMD" placed inside sealed envelope no.1.
3. Financial bid in prescribed format in sealed envelope no.2.

We hereby agree to fully abide by all the terms & condition of this tender.

Thanking you,

Yours faithfully,

Name.....
Designation.....

Signature of Bidder
Seal of Bidder

Annexure-IV**Proforma for Bank Guarantee**

In consideration of the National Small Industries Corporation Ltd. (NSIC), Okhla Industrial Estate, New Delhi (hereinafter called the 'Company') having agreed to exempt-----
 ----- (hereinafter called the said 'Contractor' which term includes Suppliers for the purpose of this Bond) from the demand under the terms and conditions of an Agreement date. ----- Made between -----
 -----and ----- for (hereinafter called the said 'Agreement') of Security Deposit for the due fulfillment by the said Contractor of the terms and conditions contained in the said Agreement, on production of a Bank Guarantee for Rs. -----
 ----- (Rupees-----only).

a. We, _____(Indicate the name of the Bank)_____ (hereinafter referred to as the 'Bank') at the request _____(Contractor(s)) do hereby undertake to pay to the Company an amount not exceeding Rs. _____ against any loss or damage caused to or suffered or would be caused to or suffered by the Company by reason of any breach by the said Contractor (s) of any of the terms and conditions contained in the said Agreement.

b. We, _____(indicate the name of the Bank)_____ do hereby undertake to pay the amounts due and payable under this guarantee without any demur, merely on a demand from the Company stating that the amount claimed is due by way of loss or damage caused to or would be caused to or suffered by the Company by reason of breach by the said Contractor(s), of any of the terms of conditions contained in the said Agreement or by reason of the contractor(s), failure to perform the said Agreement. Any such demand made on the Bank shall be conclusive as regards the amount due and payable by the Bank under this guarantee. However, our liability under this guarantee shall be restricted to an amount not exceeding Rs._____.

c. We undertake to pay to the Company any money so demanded notwithstanding any dispute or disputes raised by the Contractor(s) in any suit or proceeding pending before any court or Tribunal relating thereto our liability under this present being absolute and unequivocal.

The payment so made by us under this bond shall be a valid discharge of our liability for payment there under and the Contractor(s) shall have no claim against us for making such payment.

Signature of Bidder
Seal of Bidder

d. We, _____(indicate the name of the Bank)_____ further agree that the Guarantee herein contained shall remain in full force and effect during the period that would be taken for the performance of the said Agreement and that it shall continue to be enforceable till all the dues of the Company under or by virtue of the said Agreement have been fully paid and its claims satisfied or discharged or till _____ National Small Industries Corporation Ltd. (NSIC) certifies that the terms and conditions of the said Agreement have been fully and property carried out by the said contractor(s) and accordingly discharged this guarantee. Unless a demand or claim under this guarantee is made on us in writing on or before the _____ we shall be discharged from all the liability under this guarantee thereafter.

e. We, _____(indicate the name of the Bank)_____ further agree with the Company that the Company shall have the fullest liberty without our consent and without affecting in any manner our obligations hereunder to vary any of the terms and conditions of the said Agreement or to extend time of performance by the said contractor(s) from time to time or to postpone for any time or from time to time any of the power exercisable by the company against the said contractor(s) and to forbear or enforce any of the terms and conditions relating to the said Agreement and we shall not be relieved from our liability by any reason of any such variation or extension being granted to the said contractor(s) or for any forbearance, act or omission on the part of the company or any indulgence by the company to the said contractor(s) or by any such matter or thing whatsoever which under the law relating to sureties would but for this provision have effect of so relieving us.

f. This guarantee will not be discharged due to the change in the constitution of the Bank or the contractor(s).

g. We, _____(indicate the name of the bank)_____ lastly undertake not to revoke this guarantee during its currency except with the previous consent of the Company in writing.

Dated the _____ day of _____
For _____(indicate the name of the bank)_____

Signature of Bidder
Seal of Bidder

Lunch Box Assembly

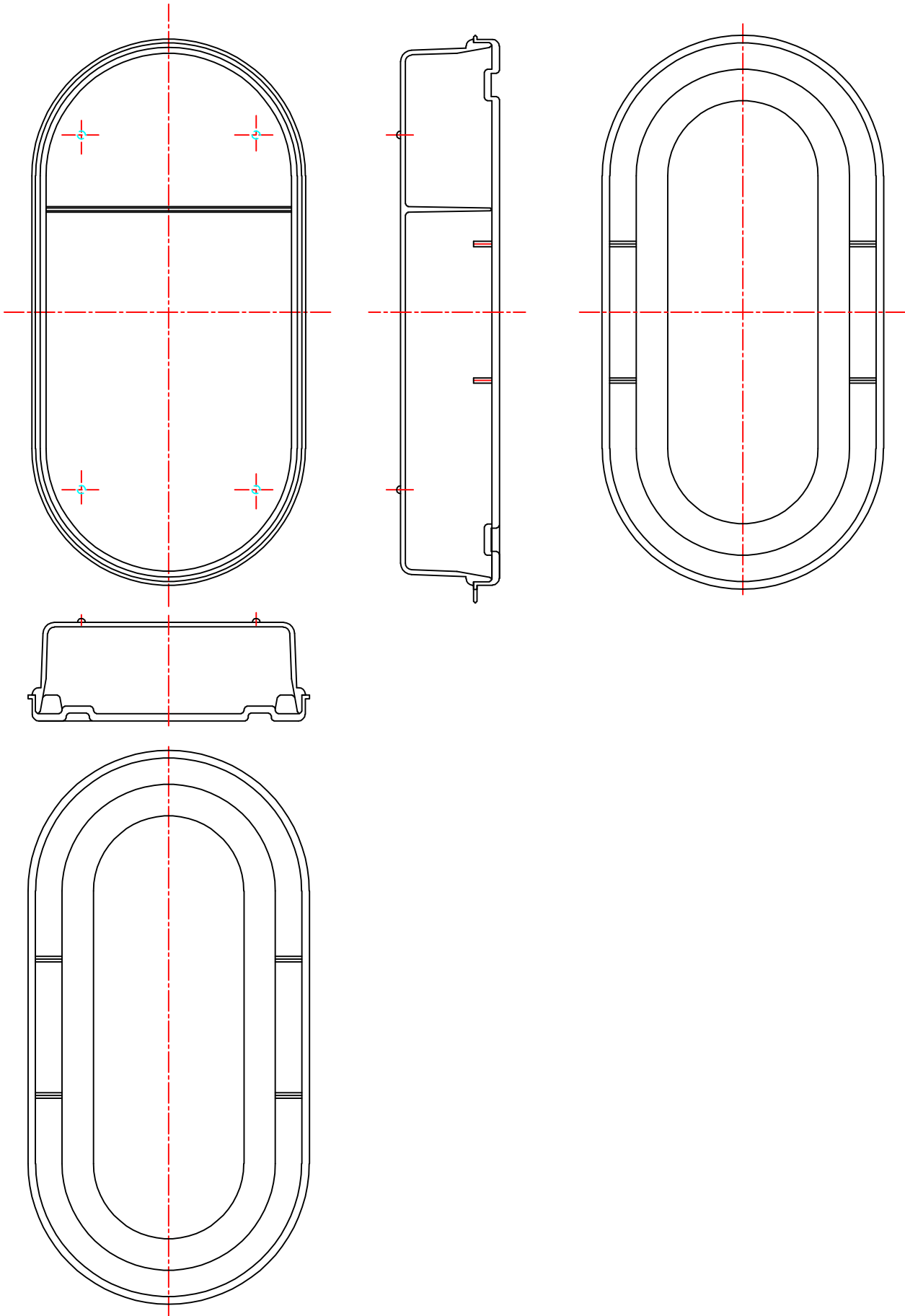

Lunch Box Base and Top

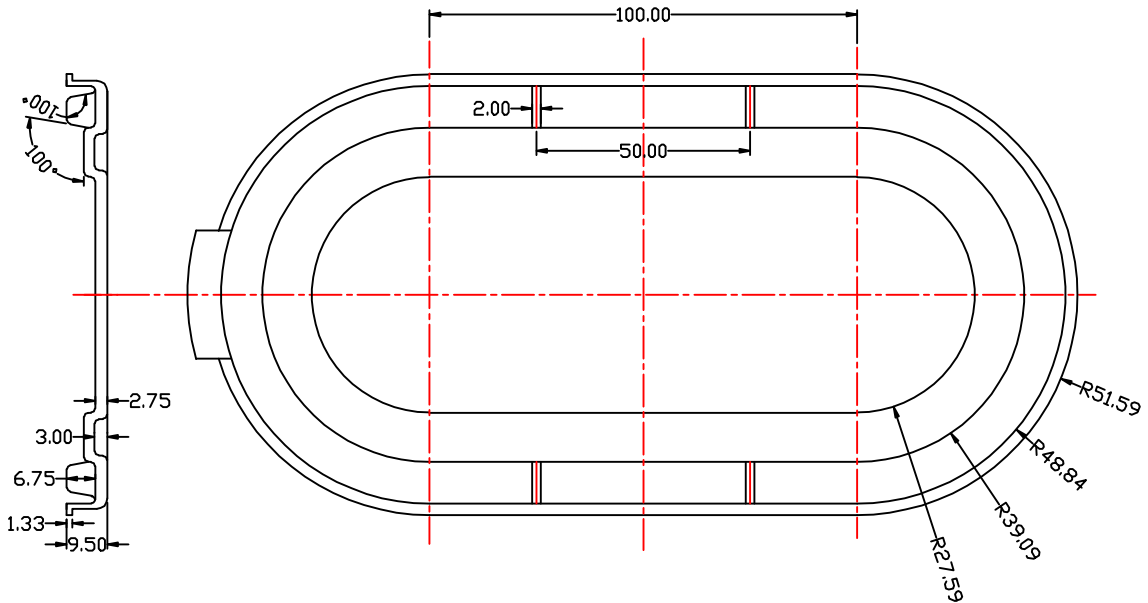
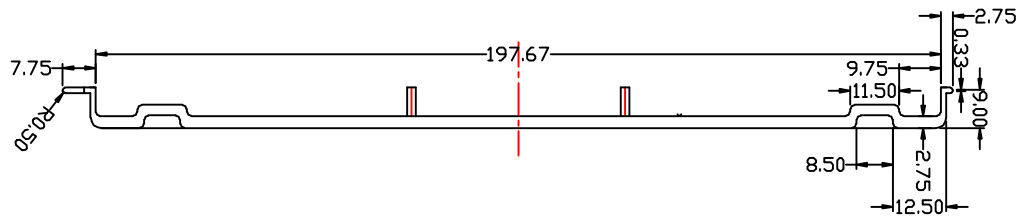
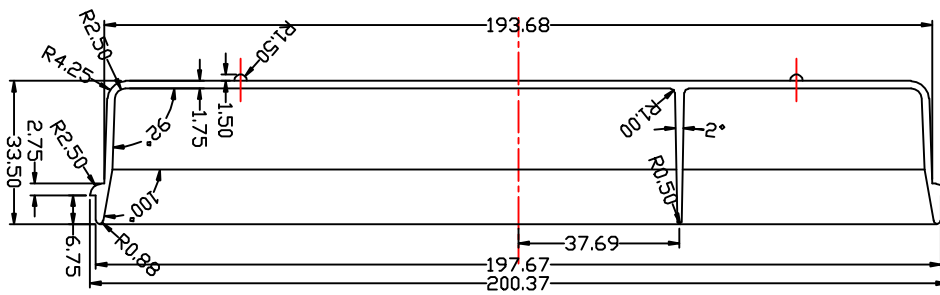
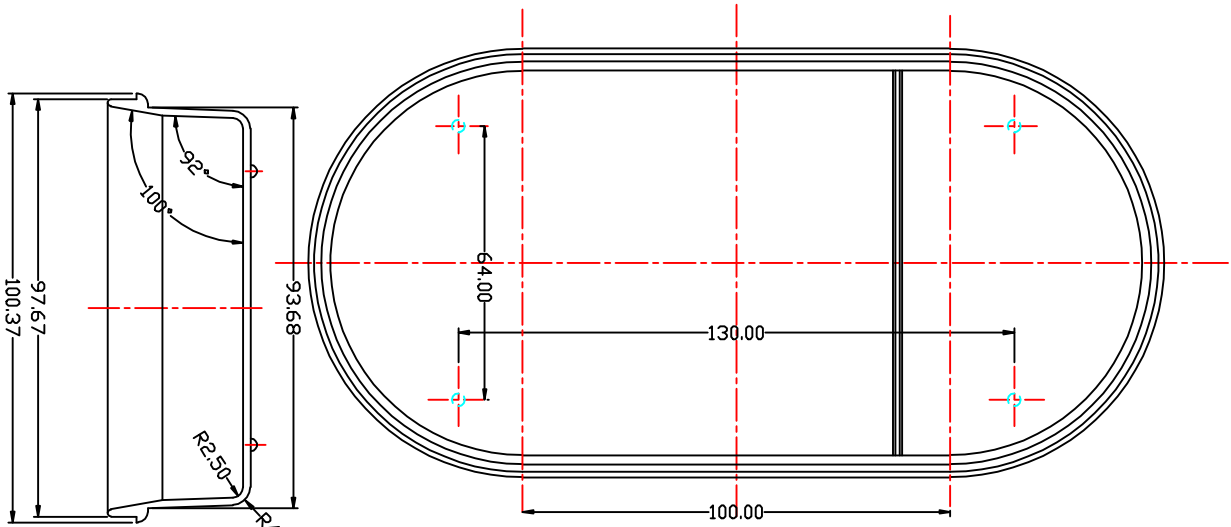

Lunch Plate

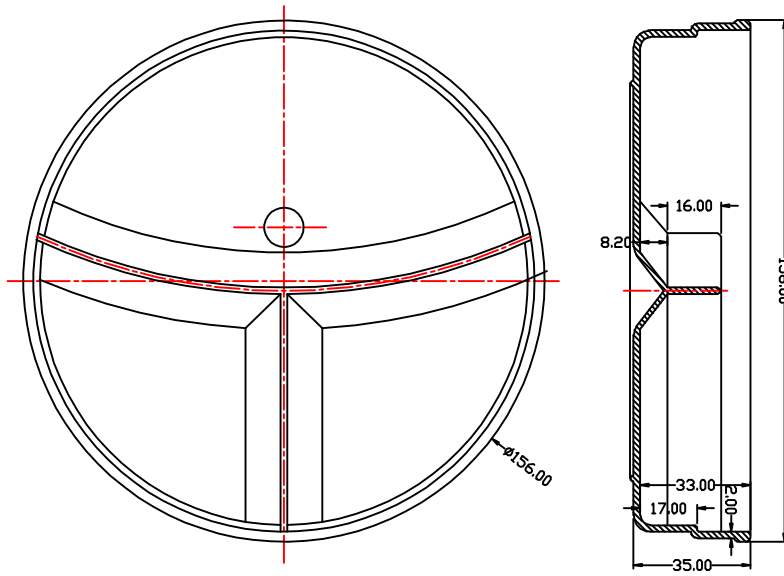

Bowl

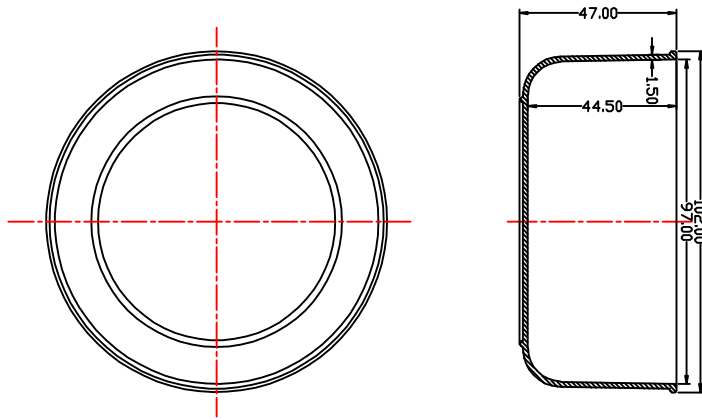

Cup

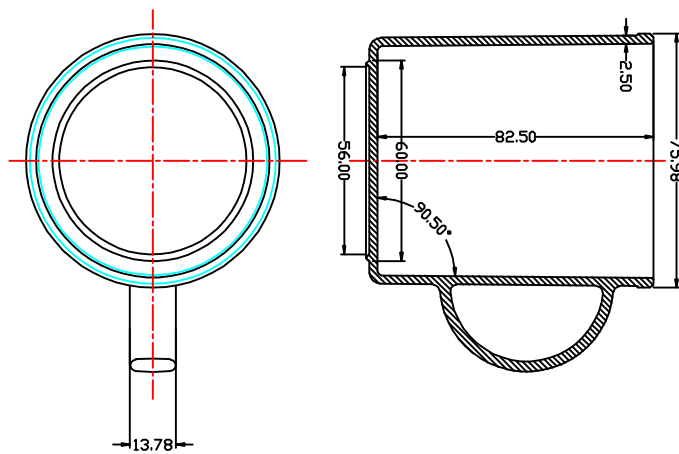

"OPTIMA" SERIES INJECTION MOLDING MACHINES - TECHNICAL SPECIFICATIONS

Machine Model		OPTIMA 45			OPTIMA 45H			OPTIMA 75			OPTIMA 75H			
International dimensions		450H-110			450H-128			750H-186			750H-200			
Injection unit number		110			128			186			200			
Injection unit		A	B	C	A	B	C	A	B	C	A	B	C	A
Screw diameter	mm	28	31	35	28	31	35	31	35	40	31	35	40	40
Screw L/D ratio	L/D	21	19	17	21	19	17	22	19	17	22	19	17	20
Stroke volume	cm ³	68	83	106	68	83	106	102	130	170	102	130	170	203
Injection weight max.*	g	64	79	100	64	79	100	97	123	161	97	123	161	193
Injection rate #	cm ³ /s	45	56	71	53	65	83	56	72	94	70	89	116	67
Plasticizing rate #	g/s	5.2	6.3	8.0	5.3	7.5	9.6	6.1	9.0	9.9	7.2	10.7	11.8	11.5
Injection pressure	bar	1618	1320	1036	1897	1548	1214	1826	1433	1097	1961	1539	1178	2042
Screw rpm	min-1	160			180			160			190			
Clamping unit														
Clamping force	kN	450			450			750			750			
Mold opening stroke	mm	220			220			300			300			
Dist. Bet. Tie bars, H X V	mm	300 X 234			300 X 234			350 X 310			350 X 310			
Mold thickness, min. - max.	mm	150-300			150-300			125-310			125-310			
Ejector stroke	mm	50			50			65			65			
Ejector force	kN	28			33			26			28			
Ejector number	pcs	1			1			1			1			
General data														
Pump drive	kW	5.50			7.50			7.50			9.30			
Installed heating capacity	kW	4.94			6.46			6.48			7.65			
Total connected power	kW	10.44			13.96			13.98			16.95			
Machine dimensions, LXWXH	m	3.5 X 1.5 X 1.7			3.5 X 1.5 X 1.7			3.5 X 1.6 X 1.8			3.5 X 1.6 X 1.8			
Oil tank capacity	l	150			150			200			200			
Net weight (without oil)	t	2.8			2.8			3.7			3.7			

NOTE :

Achieved in air injection. * Theoretical value; actual value may vary depending on material, melt density & residence time • Figures in BOLD indicate standard scope of supply.

<p>Platen Dimensions</p> <p>Moving Platen</p>		
<p>Platen Dimensions</p> <p>Stationary Platen</p>		
<p>Machine Dimensions</p>		

