

Tender Notice

NSIC Technical Services Centre Okhla Industrial Estate, Phase-III, Near Govindpuri Metro Station, New Delhi-110020

Tel: +91-11-26826796/26826801/26826848

Email: ntscok@nsic.co.in

Tender no. : NTSC (O)/EM/F&F/2015-16

Date: 8th June, 2015

Subject: Supply of Class room desks at NSIC Technical Services Centre Okhla Industrial Estate, P-III, Near Govindpuri Metro Station, New Delhi-110020.

We are pleased to invite your offer in two parts viz. (a) Technical and (b) Financial, strictly as per enclosed terms and conditions, in sealed covers for the supply of Class room desks at NSIC Technical Services Centre Okhla Industrial Estate, Phase-III, Near Govindpuri Metro Station, New Delhi-110020

S.No	Name of work	Estimated Cost Rs (Lacs)	EMD (Rs)	Completion Time	Issue of Blank Tender Document	Last date of submission of Tender
01	Supply of Classroom desks at NSIC Technical Services centre Okhla Ind Estate P-III, New Delhi-20	5.00	12500	30 days	08.06.2015 to 22.06.2015 up to 2.00 PM	22.06.2015 up to 3.00 PM

The detailed tender document can be obtained from Chief Manager (Training) at the above address. The tender document can also be downloaded from NSIC website www.nsic.co.in. Any clarification on technical specifications can be obtained in writing from NSIC Technical Services Centre Okhla New Delhi, before submission of tender.

Please submit your lowest quotation / offer for the above requirement subject to our terms and conditions. Your offer should be submitted to General Manager, NSIC Technical Services Centre Okhla Industrial Estate, Phase-III, Near Govindpuri Metro Station, New Delhi-110020, NSIC Bhawan, Okhla Industrial Estate, New Delhi-110020 latest by 22nd June, 2015 till 3.00 P.M.

Signature of Bidder
Seal of Bidder

Offers received after the last date and scheduled time shall not be considered.

The offer for technical bid shall be submitted in a **sealed envelope clearly mentioning the above tender number on top of the envelope**. Bidder shall sign on all pages & place technical & financial bid in a separate envelope.

The Technical bid shall be opened on 22nd June, 2015 at 5:00 P.M. in the presence of authorized representatives of the bidders who may like to be present. The financial Bid shall be opened on a specified date intimated later on.

Blank tender documents (non-transferable) shall be issued from 08.06.2015 To 22.06.2015 up to 2.00 P.M. on working days from the address given below on payment of required tender fee of Rs. 500/- (Rupees Five Hundred only) (non-refundable) in form of DD/pay order/bankers cheque in favour of "NSIC LTD. A/C NTSC", payable at New Delhi. The intending tenderers can also down load the complete tender documents available on the web site ***www.nsic.co.in*** and submit the same along with tender fee and requisite earnest money deposit by the due date.

Intending tenderers should have valid registration with Sales tax/Works Contract tax authorities.

Note: The vendor should submit their best price while submitting their bids itself and they will not be allowed to revise the price any time thereafter.

General Manager NSIC Technical Services Centre reserves the right to reject one or all of the bids during any stage of above tender process without assigning any reasons.

KINDLY READ ALL TERMS AND CONDITIONS OF "TENDER DOCUMENT" THOROUGHLY. QUOTATION NOT IN ACCORDANCE WITH THE TERMS AND CONDITIONS IS LIABLE TO BE DISQUALIFIED AND IGNORED.

**GENERAL MANAGER,
NSIC TECHNICAL SERVICES CENTRE
Okhla Industrial Estate, Phase III,
Near Govindpuri Metro Station,
New Delhi-110020**

Signature of Bidder
Seal of Bidder

Terms & Conditions for submission of tender

1) Preparation of Bids:

The bids should be prepared in the following manner:-

- a. The Bid shall be neatly arranged & clearly filled up as per format given at page no 10 of this tender.
- b. Each page of the bid should be signed by the authorized person.
- c. Insertions, postscripts, additions and alterations shall not be recognized, unless confirmed by bidder's signature.
- d. Bids should not contain any terms and conditions, printed or otherwise, which are not applicable to the Bid.
- e. Any conditional bid not adhering to the terms & conditions of the tender or part bid shall be rejected.
- f. The bidder is required to submit at least three reference of the past supply of items for the furniture or similar specification giving details of customer. In support bidder has to submit copies of such supplies or ITR form for the last three years.
- g. In the financial bid, prices are to be indicated in both figures and words. In case of any discrepancy of value the prices quoted in words shall be considered for evaluation and establishing L1 status.
- h. No price variation clause will be entertained.
- i. Specifications are mentioned in the drawing attached with the tender. If at any stage if it is found that product (classroom desks) are not as per dimensions or material mentioned in this tender, the whole process would be scrapped & decision of General manager NSIC Technical Services Centre, would be final & absolute.
- j. Bid with any pre-conditions (like conditional discounts) for price are liable to be "Not considered/Rejected".

2) Submission of Bids:

- a. Bids must be received by NSIC Technical Services Centre on or before the due date and time at the address specified in the tender document. In the event of the specified date for the submission of bids being declared a holiday for NSIC Technical Services Centre, the bid-closing deadline will stand extended to the next working day up to the same time.

Signature of Bidder
Seal of Bidder

- b. Any bid received by NSIC Technical Services Centre after the deadline for submission of bids, will not be accepted and returned unopened to the bidder.
- c. NSIC Technical Services Centre at its discretion may extend the deadline for the submission of bids if the bid document undergoes changes during the bidding period, in order to give prospective bidders time to take into consideration the amendments while preparing their bids.
- d. In case of receipt of inadequate numbers of bids, NSIC Technical Services Centre may extend the deadline for submission of bids giving opportunity to other bidders to participate in the bidding process to make it competitive.

NOTE: The bidders should submit their best price at this stage itself and they will not be allowed to revise the price. Any revision / Discount given by supplier subsequently will be ignored.

- e. If the bidder submits only one envelop / cover containing all the bids or combined bids e.g. techno-commercial bid & price bid together, the bid is liable for rejection.
- f. Bidder shall submit a separate envelope containing Demand draft of Rs 12,500/- as EMD. The cost of tender i.e. Rs 500/- in the form of Demand draft or cash receipt issued by NSIC Technical Services Centre also be enclosed in the envelope.
- g. All the three envelopes (I) Technical bid (II) Price bid (III) EMD & Cost of tender shall be placed in a bigger envelope.**

3) Bid opening and evaluation of Bids:

- a. The Technical bids shall be opened on 22nd June, 2015 at 5:00 P.M.
- b. Bidder, whose technical bid is qualified as per terms & condition specified in this tender document, will be considered for financial bid evaluation. The date and time of opening of the financial bid will be informed separately to such bidders.

Signature of Bidder
Seal of Bidder

- c. NSIC Technical Services Centre will open financial bids of only the technically qualified, in the presence of the bidders or their authorised representative who choose to attend the bid opening.
- d. The bidder's authorised representative who attends the bid opening shall sign an attendance register as a proof of having attended the bid opening.

4) Award of Contract

- a. The financial bids of the technically qualified bidders shall be opened by the constituted committee. Thereafter the committee shall prepare the comparative statement (CST) based on the price offered at NSIC Technical Services Centre, Okhla Ind. Estate P-III, New Delhi-110020. This will facilitate to shortlist the bidder quoting the lowest price.
- b. L-1 will be decided on the basis of final prices/ value quoted in the price bid.
- c. NSIC Technical Services Centre shall award the contract to the eligible bidder whose bid has been accepted and determined as the lowest evaluated financial bid.
- d. If more than one bidder happens to quote the same lowest price, NSIC Technical Services Centre reserves the right to award the contract to any one bidder. No representation in this regard shall be entertained for any reason.
- e. Supply order shall be placed for supply of class room desks required at NSIC Technical Services Centre Okhla Industrial Estate, Phase-III, Near Govindpuri Metro Station, New Delhi-110020. EMD amount of Rs 12,500/- would be kept as "Security Deposit" for a period of one year against the supply orders placed.
- f. The successful bidder, on award of contract/order, must send the supply order acceptance in writing, within 7 days of award of supply order, failing which the EMD will be forfeited.
- g. **Committee constituted by General Manager has authority to take a call on the item i.e. classroom desks offered in the technical bid. Committee decision will not be challengeable and binding to all concerned without any liability to justify so.**

Signature of Bidder
Seal of Bidder

5) Interpretation of the clauses in the Tender Document / Contract Document

In case of any ambiguity/ dispute in the interpretation of any of the clauses in this Tender Document, NSIC Technical Services Centre interpretation of the clauses shall be final and binding on all parties.

6) Earnest Money Deposit:

a. The units registered with Central Purchase Organization (DGS&D), National Small Industries Corporation (NSIC) or the concerned Ministry or Department shall be exempted from the payment of Earnest Money as defined under Rule 157 of General Financial Rules (GFR), 2005.

In such case, copy of the certificate showing registration with the above mentioned institutions to be enclosed in the envelope of EMD & Tender cost.

b. In case, the unit is not covered under 6 (a). above, it should submit the offer along with Earnest Money Deposit (EMD) for Rs. 12,500/- (Rupees Twelve Thousand Five Hundred only) by way of Demand Draft (DD) drawn in favour of "NSIC Ltd A/c NTSC" payable at New Delhi. No cash / cheque towards EMD shall be accepted. The DD for EMD & Cost of tender should be placed inside a separate envelope. The offers without EMD & cost of tender shall be rejected.

c. The EMD of unsuccessful bidder shall be refunded within 30 days from the award of contract.

d. No interest will be allowed for earnest money deposited with the Company.

e. The EMD shall be forfeited:

1. If the bidder withdraws the bid during the period of bid validity specified in the tender.

2. If the successful bidder fails to furnish the acceptance in writing, within 7 days of award of contract/order.

3. If the successful bidder fails to deliver supplies as per Supply order.

7) Security Deposit

a. Total security money shall be Rs 12,500/-. The EMD of successful bidder shall be kept as "Security Deposit" for supply of classroom desks against supply order and shall be released after a year from the date of supply.

Signature of Bidder
Seal of Bidder

8) Prices:

All items are to be quoted in INR only in the format as per Annexure-I. The price quoted should be inclusive of packing, insurance and freight on FOR, NSIC Technical Services Centre Okhla Industrial Estate, Phase-III, Near Govindpuri Metro Station, New Delhi-110020. **The prices should also be inclusive of all taxes and duties as applicable.** The price quoted shall be considered firm and no price escalation shall be permitted.

9) Validity of the Quote:

The validity of quote should be at least six months (180 days) from the closing date of tender. A bid valid for a shorter period shall stand rejected.

NSIC Technical Services Centre may ask for the bidder's consent to extend the period of validity. Such request and the response shall be made in writing only. A bidder agreeing to the request for extension will not be permitted to modify his bid.

10) Delivery period:

The classroom desks shall be delivered to NSIC Technical Services Centre, Okhla Industrial Estate, Phase-III, Near Govindpuri Metro Station, New Delhi-110020 within 30 days from the date of award of contract. Part delivery shall not be permitted. Inspection of goods shall be carried out at NSIC Technical Services Centre Premises. No other delivery terms shall be acceptable.

The supplier shall be competent enough to supply desks in a span of 30 days period after placing the supply order as detailed under:-

S.No	Name of item	Quantity
01	Classroom desks	100 No.

11) Taxes / Duties:

- a. The bidders should be registered with sales tax / income tax department of Govt. of India and should hold a valid registration certificate, as applicable.
- b. Sales tax, excise duty, octroi or any other tax shall be paid on actual as per rule applicable and on production of documentary proof. **No tax concession/form shall be issued.**

12) Payment terms:

100% of order value to be released on submission of following documents:

Signature of Bidder
Seal of Bidder

- i. Signed commercial Invoice - two copies certifying that the goods are exactly as per the supply order and the specification quoted.
- ii. Proof of delivery of the supply in totality to our representative at NSIC Technical Services Centre, Okhla Industrial Estate, Phase-III, Near Govindpuri Metro Station, New Delhi-110020.
- iii. Inspection report issued by representative of NSIC Technical Services Centre.
- iv. Warrantee document for a period of minimum one year against any defect in material.
- v. Testing reports of material used for supply is mandatory from NABL Accredited lab while submitting the bills. NSIC Technical services Centre also provide testing facility under NABL accreditation.

The quality of desks shall be of good quality. In case quality of desks & material used found to be inferior during inspection, the whole supply order or part thereof shall be rejected without assigning any reasons. Accordingly, the supply order shall be treated as cancelled without any liability on NSIC Technical Services Centre.

13) Liquidated damages:

In the event of delay in supply of the goods within the stipulated period, Liquidated Damages (LD) shall be charged by NSIC @ ½% (one-half of one percent) of the total order value per week of delay or part thereof.

14) Insurance:

Whole supply order to be insured for 100% of the FOR value up to the premises of NSIC Technical Services Centre Okhla Industrial Estate, Phase-III, Near Govindpuri Metro Station, New Delhi-110020.

15) After Sales Service / Warranties by Suppliers:

The classroom desks shall be warranted for any manufacturing defect for a period of 12 months from the date of supply at site. Should any part or parts fail or proved defective within the period specified above, owing to defect in design, material or workmanship, the supplier will have to replace them at the place of installation free of all charges. The security money shall be kept during the warrantee period.

16) Risk Purchase:

In case of delays in supplies / defective supplies or non-fulfillment of any other terms and conditions given in the Supply Order, NSIC Technical Services Centre may cancel the supply order in full or part thereof, and may also make the purchase of such material from elsewhere / alternative source at the risk and cost of the supplier.

Signature of Bidder
Seal of Bidder

In case vendor does not agree to above risk purchase clause, their offer is liable to be rejected. In case any vendor accepts risk purchase clause initially and subsequently declines to honour the term in the eventuality of RISK PURCHASE, they may be banned for business with NSIC.

17) Cancellation of Bids

- a. NSIC Technical Services Centre reserves the rights to cancel any bid without assigning any reasons.
- b. NSIC Technical Services Centre reserves the rights to cancel bids and refloat a fresh tender, at any time after opening of the bids, in case it finds the response to its bid are not meeting its requirement. This shall be at the sole discretion of NSIC Technical Services Centre.

18) Blacklisting / Debarring of Firm

- a. Units blacklisted by any Government Departments / PSUs are not eligible to participate in the tender.
- b. If the unit(s) commits breach of contract, it shall be black listed / debarred for further business with NSIC for a declared period.

19) Dispute Redressal :

In event of any dispute, the legal matter shall be subjected to the Jurisdiction of Delhi Courts only.

Signature of Bidder
Seal of Bidder

Please tick mark ✓ on the following parameter for supply of Class room desks at NSIC Technical Services Centre Okhla Industrial Estate, P-III, Near Govindpuri, Metro Station, New Delhi-110020.

S.No	Parameter	Yes	No
01	Supply shall be as per Specification in terms of colour & Dimensions attached with this tender		

Technical bid Enclosure:-

1. Copy of Pan Card / Sales tax / VAT registration certificate.
2. Copy of SSI/MSME Memorandum part – II /NSIC registration certificate, if applicable.
3. Authorization letter in favour of authorized signatory from the bidder.
4. Duly signed & stamped from page no 1 to 14 of this tender.
5. Last three Supplies copies of similar nature.
6. Annexure "1", undertaking by the bidder.

Signature of Bidder
Seal of Bidder

Undertaking letter

Ref.: Tender No. NTSC (O)/EM/F&F/2015-16 dated 8th June, 2015
for Supply of Class room desks at NSIC Technical Services
Centre Okhla Industrial Estate, P-III, Near Govindpuri Metro
Station, New Delhi-110020.

We declare that we are not a defaulter to any Government
organization/ PSU since last three years from the date of issue of
this tender no NTSC(O)/EM/ F&F/ 2015-16 due to non-supply of
material for any reason.

We hereby agree to fully abide by all the terms & condition of this
tender. Thanking you,

Signature.....

Name.....

Designation.....

Signature of Bidder
Seal of Bidder

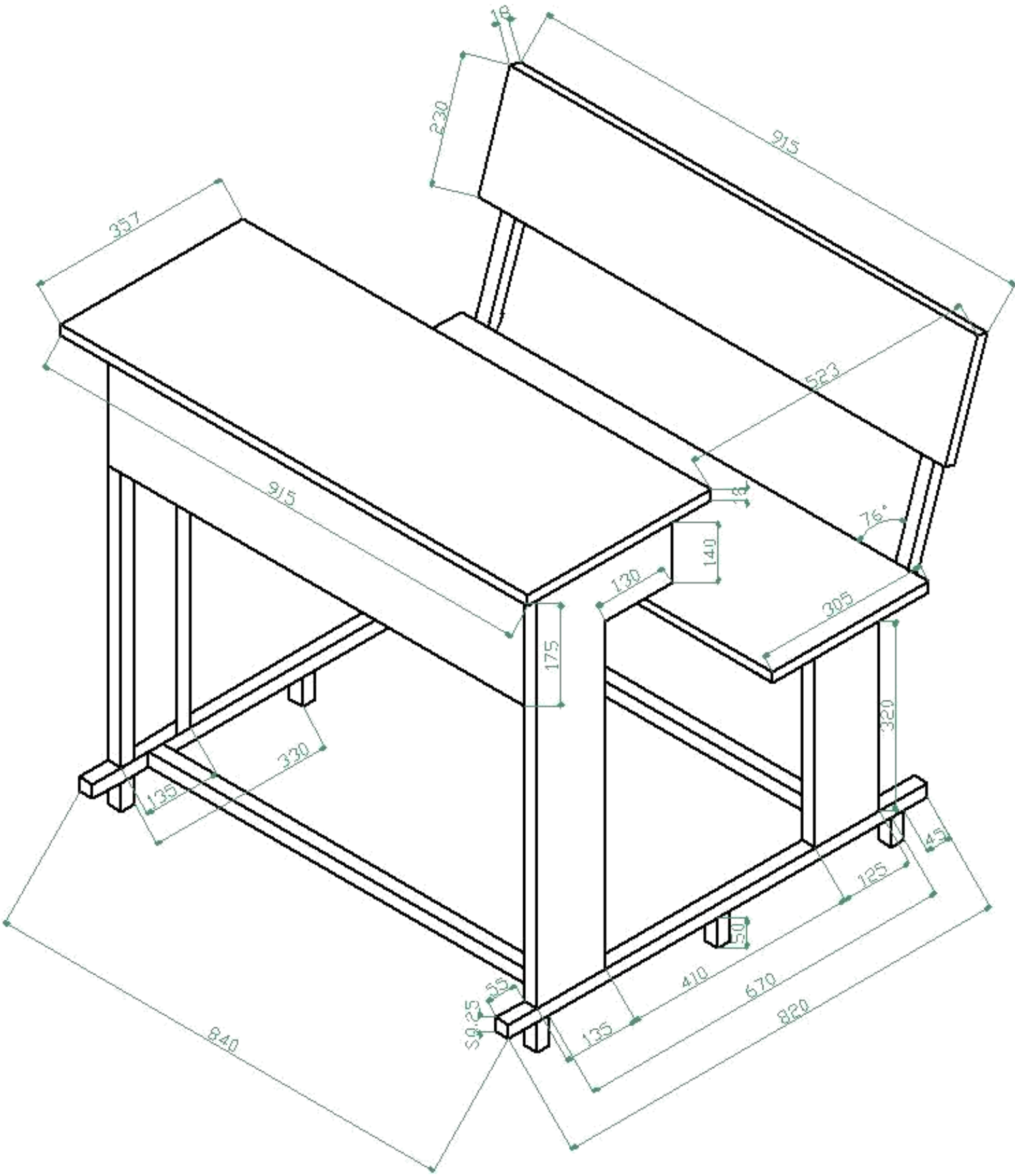

Signature of Bidder
Seal of Bidder

PART LIST			
SN.	PART NAME	MATERIAL	NO/OFF
1	PLYWOOD	PLYWOOD	1
2	PLYWOOD	PLYWOOD	1
3	PLYWOOD	PLYWOOD	1
4	METAL SHEET	IRON	1
5	METAL SHEET	IRON	1
6	METAL SHEET	IRON	1
7	METAL SHEET	IRON	2
8	METAL SHEET	IRON	2
9	METAL SHEET	IRON	2
10	ANGLE PLATE	IRON	3
11	SQ. METAL ROD	IRON	2
12	SQ. METAL ROD	IRON	2
13	SQ. METAL ROD	IRON	2
14	SQ. METAL ROD	IRON	6

WOODEN

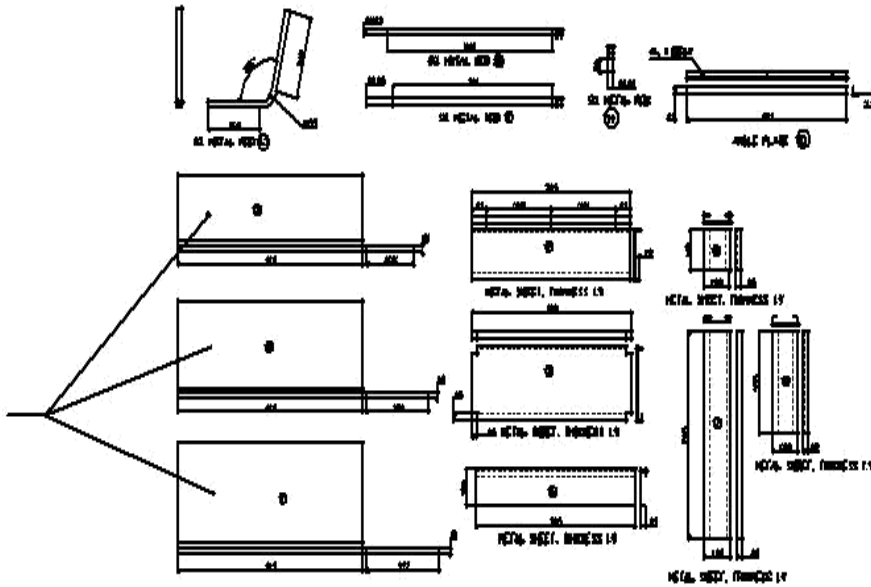
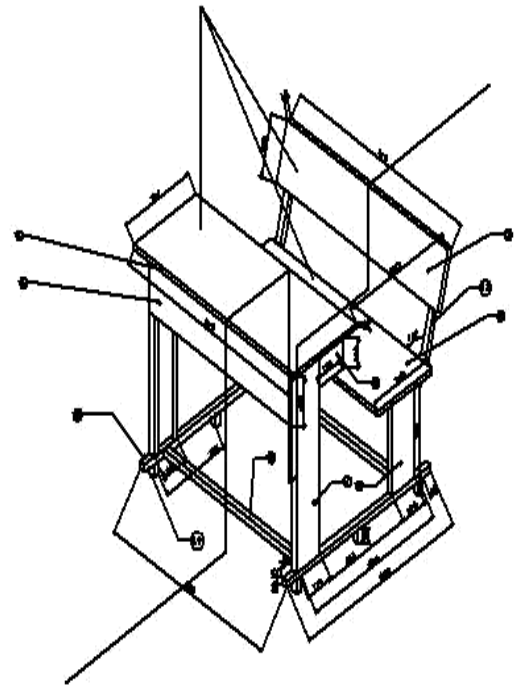

Signature of Bidder
Seal of Bidder



(Sample Piece)

Signature of Bidder
Seal of Bidder

Financial price schedule**Supply of Class room desks at NSIC Technical Services Centre Okhla Industrial Estate, P-III, Near Govindpuri Metro Station, New Delhi-110020:**

S.No	Description of item	Quantity	Rate(Rs) per Unit	Total Rate (Rs)
	A	B	C	D=BxC
01	Supplying and placing in position of three seater class room desks square pipe 16 SWG and Iron sheet 16 SWG with MDF board both side laminated in blue sheet as per dimensions mentioned in the drawing attached with this Tender.	100 Nos		
02	Taxes & Duties			
03	Transportation/Cartage or any other charges.			
04	Grand Total (1+2+3)			

Amount in words:.....

Validity of offer: 180 days

Delivery Period: 30 days period after placing the supply order.

Note: The above price should be inclusive of packing, transportation, insurance, taxes & duties etc. **No tax concession /form shall be issued.**

Signature of Bidder
Seal of Bidder