

**TENDER
FOR
SUPPLY OF FOUR SEATER
COMPUTER TABLE**

Ref. No: NTSC/OK/COMP/TRG/2016-17/29

NSIC- Technical Services Centre
(A Government of India Enterprise)
Okhla Industrial Estate, Phase – III,
Near Govindpuri Metro Station,
New Delhi-110020

Tel No. 011-26826847, 26826801
Fax: - 011-26826783

Website: www.nsic.co.in
Email: ntscok@nsic.co.in

Signature of the Tenderer,
Name, Designation of the Signatory,
Seal of the Company,
Date:



INDEX

S. No.	Description	Page Nos.
1	Tender Inviting Notice	03
2	Instructions to the Tenderer	04 to 06
3	Terms & Conditions	07 & 08
4	Technical Bid Annexure - "A"	09 & 10
5	Commercial Bid Annexure - "B"	11
6	Undertaking Annexure - "C"	12
7	Four Seater Computer Table Drawing and Specification of Material Annexure - "D"	13 to 15

Signature of the Tenderer,
Name, Designation of the Signatory,
Seal of the Company,
Date:



TENDER INVITING NOTICE

Subject: -Tender for supply of Four Seater Computer Table.

NSIC-Technical Services Centre (NTSC), Okhla, New Delhi is a Govt. of India Institute for imparting Technical training and rendering services to MSME.

Sealed quotations are invited in two Bids system (Technical & Commercial Bid in two separate sealed envelopes contained in one bigger envelope) from furniture Manufacturer/ Supplier for **Supply of Four Seater Computer Table. Noticeable points of the tender are:**

Requirement	Supply of Four Seater Computer Table Details as per enclosed Annexure - "A" .
Tender Documents Download	Tender documents can be downloaded from 20 th December, 2016, From website www.nsic.co.in/tender archivehive.asp
Technical Bid	The details for submission of Technical Bid is placed at Annexure-"A"
Commercial Bid	The details for submission of Commercial Bid is placed at Annexure-"B"
Undertaking	The details for submission of Undertaking is placed at Annexure-"C"
Cost of Tender Documents	Rs. 500/- (Rupees Five Hundred Only) (Registered Bidders will be exempted as detailed in "Instructions to the Tenderers" at Page no 4 / Sl. No. 2)
Earnest Money Deposit along with Tender	Rs. 25,000/- (Rupees Twenty Five Thousands Only) (Registered Bidders will be exempted as detailed in "Instructions to the Tenderers" at Page no 4 / Sl. No. 2)
Last date of submission of Tender	10th January, 2017 up to 14:00 hours
Date of opening of Technical Bid	10th January, 2017 at 15:00 hours
Address for Tender inquiry, opening of Bids and Delivery of Four Seater Computer Table.	General Manager, NSIC- Technical Services Centre, Okhla Industrial Estate, Phase-III, Near Govindpuri Metro Station, New Delhi-110020. Telephone no. 011-26826847, 26826801
General Manager Tender Inviting Authority	

Signature of the Tenderer,
Name, Designation of the Signatory,
Seal of the Company,
Date:



INSTRUCTIONS TO THE TENDERER

The Tender invited from furniture Manufacturer/ Supplier for **Supply of Four Seater Computer Table:**

1. Tender Documents download:-

The tender documents can be downloaded from our website www.nsic.co.in/tenders-archive.asp w.e.f. 20th December, 2016 to 10th January, 2017.

2. Tender Fee & Earnest Money Deposit (EMD):-

Tender documents **fee of Rs. 500/-** (Rupees five hundred only) and the Earnest Money Deposit (EMD) of **Rs. 25,000/-** (Rupees Twenty Five Thousands Only) shall be paid through RTGS/NIFT/Digital/ means on or before 10th January, 2017 up to 14: 00 hours. The detail of bank account is as under:

Name (Favoring)	NSIC Ltd.-NTSC A/c
Bank Address	Punjab National Bank, NSIC Bhawan, Okhla Industrial Estate, New Delhi-110020.
A/c No.	0602002100009880
MICR Code	110024073
IFS Code.	PUNB0060200

Note: In case of transfer of money towards Tender fee and EMD by above means, participating unit name should be clearly reflected in narration and information must be forwarded through E-mail: ntscok@nsic.co.in along with bank details by mentioning Tender fee and EMD towards supply of Four Seater Computer Table.

Or

The Tender Fee/Earnest Money Deposit may be deposit by way of Demand Draft drawn in favor of NSIC Ltd. - NTSC A/C payable at New Delhi and Demand Draft shall be submitted along with Technical Bid.

3. Acceptation of Tender:

Any cutting/over writing in the tender must be signed by the person who is signing the tender. The rates and units shall not be overwritten. The financial figures in Commercial Bid shall always be both in figures and words. In case of any discrepancy in figures and words, the amount written in words shall be considered.

4. Signed and Sealed:

Tender shall be duly filled in all respect. All pages of the Tender should be signed by the Authorized Signatory of Tenderer with Company Seal as mentioned on the bottom of every pages.

5. Earnest Money Deposit (EMD):-

- The offers without EMD will be rejected.
- However, there is exemption of Tender Fee and EMD applicable to the units bearing Udyog Aadhar or registered with Central Purchase Organization (DGS&D), National Small Industries Corporation (NSIC) or the concerned Ministry or Department as defined under Rule 157 of General Financial Rules (GFR), 2005,

Signature of the Tenderer,
Name, Designation of the Signatory,
Seal of the Company,
Date:



- c) To avail exemption of Tender Fee/ EMD a photo copy of valid certificate as mentioned in at **Page no. 4 S.L no. 5 (b)** need to be attached with Technical Bid.
- d) Any request by the bidders to consider their EMD furnished by them to NTSC for any other Contract/ tender cannot be considered as EMD for this tender.
- e) No interest shall be paid for earnest money deposited by the tenderer.
- f) EMD will be refunded to the unsuccessful bidders after the supply order placed on the successful bidder.
- g) In case of successful bidder, the EMD will be refunded along with release of payment as per terms & conditions of Tender at page no. 7 Of 15 after **15 calendar days** from the date of delivery of material with satisfactory performance of goods /Submission of relevant supporting documents certified by the authorized officials of NTSC Okhla.
- h) **The EMD will be forfeited in following cases:-**
- If the successful bidder fails to furnish the acceptance in writing, within **5 calendar days** of award of supply order.
 - If the bidder fails to supply the Goods due to technical specifications or delay in supply i.e. within **45 calendar days** from the date of issue of confirmed Supply Order.
 - If bidder fails to abide by the Instructions, Terms & Conditions of the award of this Tender.
 - If the bidder withdraws the bid during the period of bid validity specified in the tender.

6. Submission of Tax Documents:-

The Tenderer shall submit the copy of PAN, VAT registration along with the Technical Bid of the Tender document. To avail TAX exemption a copy of TAX exemption, issued by Taxation Authorities is need **to be enclosed with Technical Bid**

7. Undertaking on Tender:-

An undertaking should be furnished and submitted along with the Technical Bid by the bidder on the company letter head as per the format enclosed at **Annexure “C”**.

8. Submission of Tender:-

a) The Tender shall be placed in a properly sealed bigger envelope addressed to General Manager, NSIC-Technical Services Centre, Okhla Industrial Estate, Phase III, Near Govindpuri Metro Station, New Delhi – 110020

And

The said bigger envelope shall contain two separately sealed envelopes containing Technical Bid and Commercial Bid.

The bigger envelope shall be super-scribed as “Tender for supply of Four Seater Computer Table with its due date. The two sealed envelopes inside the bigger envelope must be super-scribed as:-

Signature of the Tenderer,
Name, Designation of the Signatory,
Seal of the Company,
Date:



Envelope No-1:- The said envelope is for Technical Bid & shall be super-scribed as “Tender for supply of Four Seater Computer Table **“TECHNICAL BID”**”.

AND

Envelope No-2:- The said envelope is for Commercial Bid & shall be super scribed as “Tender for supply of Four Seater Computer Table – **“COMMERCIAL BID”**”.

b) While submitting the Tender, if any of the prescribed conditions are not fulfilled or are incomplete in any form, the Tender is liable to be rejected.

9. Opening & Evaluation of Technical Bid:-

- a) The date of opening of Technical Bid is 29.12.2016 at 1500 Hrs.
- b) Bidder, whose Technical Bid is qualified as per terms & condition specified in this tender document, will be eligible to consider for opening of Commercial Bid, accordingly shall be intimated to the qualified bidders separately.
- c) The bidder’s authorized representative who attends the bid opening shall sign an attendance register as a proof of having attended the opening of bid.

10. Award of supply order:-

- a) The Commercial Bids of the technically qualified Bidders shall be opened by the constituted committee. Thereafter the committee shall prepare the comparative statement (CST) based on the total price inclusive of taxes and freight (landed cost) at NSIC Technical Service Centre, Okhla Ind. Estate Phase – III, New Delhi- 110020.
- b) NSIC Technical Service Centre shall award the supply order to the eligible bidder whose Commercial Bid has been accepted and determined as the lowest evaluated Commercial Bid.
- c) If more than one bidder happens to quote the same lowest price, NSIC Technical Service Centre reserves the right to award the contract to any one Bidder. No representation in this regard shall be entertained for any reason.

Signature of the Tenderer,
Name, Designation of the Signatory,
Seal of the Company,
Date:



TERMS & CONDITIONS

Submission of the duly signed tender implies that these conditions of tender have been read by the Tenderer and is aware of the scope of the supply and the quality of the material to be supplied:-

1. Payment:-

- a) 95% Payment along with EMD will be made against delivery for which the tenderer shall submit bills in duplicate (original + copy) giving the reference number of the supply order along with delivery note and all relevant documents related to Supply of Four Seater Computer Table within 15 days. Acceptance of DGM (Computer Training) is required for release of payment. Balance 5% payment shall be released after twelve months.
- b) No extra payment shall be paid on account of any discrepancy in nomenclature of items. The bidder shall seek clarifications if any before submitting the bid.
- c) The corporation will not issue Form "C" or "D"

2. Delivery Period:-

- a) The delivery period for the supplies to be completed within **45 calendar days** from the date of issue of confirmed supply order from NTSC Okhla, New Delhi -110020.
- b) In case the tenderer fails to complete the work within **45 calendar days** from the date of supply order, shall be liable to pay liquidated damages @ 0.5% (One Half of one percent only) of the value of order per week and or part thereof of the delay subject to a maximum of 2% (two percent only) of the value of the contract upto maximum period of **30 calendar days**. The amount of Compensation may be adjusted or set-off against any sum payable to the supplier under this or any other contract with the Corporation.
- c) In case tenderer fails to supply within the accepted period, General Manager of NSIC- Technical Services Centre, reserves the right to cancel the Supply Order and may initiate action to debar the supplier for all future business dealing with NSIC for next three years.

3. Services & Support:-

The supplier shall be liable for any manufacturing defect for a period of 12 months. Within this period product shall be repaired at his own cost. If product is not repaired within 3 days, it shall be repaired by us and cost shall be deducted from balance payment.

4. Validity of Tender:

Validity of tender shall be **45 calendar days** from the date of opening of Technical Bid.

5. Dispute:

In the event of any dispute at any stage the legal matter shall be subjected to the jurisdiction of Delhi Courts only.

6. Final Acceptance:

General Manager, NTSC, Okhla reserves the right without given any reason to accept or reject in full or any part of this Tender at any stage of this Tender process.

Signature of the Tenderer,
Name, Designation of the Signatory,
Seal of the Company,
Date:



7. List of Clients :

Name & Address of at least 3 clients where similar products having value more than Rs.5 lacs were supplied in last 2 years. Supporting documents should also be enclosed.

8. Pre-dispatch inspection :

A pre-dispatch inspection by 3rd party/ technical team of purchaser may be carried out at bidder's manufacturing site. This pre-dispatch inspection will not absolve bidder's responsibility to execute supply in accordance with the tender terms. NTSC shall liberty to visit to inspect the product quality according to work order at any time during the manufacturing process.

9. Change in Quantity :

Quantity of Four Seater Computer Table may increase.

Signature of the Tenderer,
Name, Designation of the Signatory,
Seal of the Company,
Date:



TECHNICAL BID

- Tender Ref. No: **NTSC/OK/COMP/TRG/2016-17/29**
- Name of Tenderer:
- Complete office address of Tenderer.....
.....
- PAN
- VAT registration number
- Contact details of authorized person of tenderer who have signed the tender.
 - a. Name.....
 - b. Designation.....
 - c. Phone (Office).....Phone (Mobile).....
 - d. E mail.....
- **Tender fee & EMD payment details:**

Tender fee & EMD payment bank details (as mentioned at page no 4 of 15) transferred to NSIC Ltd. – NTSC A/c OR Exemption certificate must be attached with Technical Bid.
- In case payment is not paid through online (RTGS/NIFT/Digital means transferred) Demand Draft must be enclosed with Technical Bid.

Signature of the Tenderer,
Name, Designation of the Signatory,
Seal of the Company,
Date:



• **Technical Specification for Supply of Four Seater Computer Table :-**

<u>Description</u>	Qty. Required	Confirm by writing YES//NO against Supply
Supply of Four Seater Computer Table As per enclosed Drawing at Annexure - "D" from Page 13-15	140 Nos.	

**** A Sample piece of Four Seater Computer Table is available at NTSC, Okhla, New Delhi -110020, Tenderer is option to visit the centre and view the sample before filling the Tender.)**

Mandatory Documents to be enclosed with the Technical Bid:-

- a) Duly signed & sealed all pages of Tender documents as a mark of your acceptance.
- b) Undertaking on letter head as per enclosed **Annexure-"C"**.
- c) Photo copies of PAN, VAT Tax exemption (if any) duly signed & Sealed by the tenderer.
- d) Photo copy of document authenticating eligibility towards Tender Fees/EMD exemption, if awarded duly signed & Sealed by the tenderer.
- e) Incase Tender fee & EMD payment made through RTGS/NIFT/Digital/ means transferred to NSIC Ltd. – NTSC A/c, Information details shall be enclosed with the Technical Bid.
- f) Incase Tender fee & EMD payment made through Demand Draft. The Demand Drafts shall be enclosed with the Technical Bid.
- g) Brief summary of your firm should also be enclosed along with Technical Bid.
- h) Name & Address of at least 3 clients where similar products having value more than Rs.5 lacs were supplied in last 2 years. Supporting documents should also be enclosed.

Signature of the Tenderer,
Name, Designation of the Signatory,
Seal of the Company,
Date:



COMMERCIAL BID

1. Tender Ref. No: NTSC/OK/COMP/TRG/2016-17/29
2. Name of the Tenderer:
3. The offer with rates for the schedule of requirements of items, as elaborated under, to be submitted. Adhering to the format given below is a Pre-requisite for considering your quotations:

Item No.	Description	Quantity Required	Amount in Rs.	
			Rate for single Qty.	Total Amount (in Rupees)
A.	<p style="text-align: center;">Supply of Four Seater Computer Table As per enclosed Drawing at Annexure - “D” from Page 13-15</p> <p>(A Sample piece of Four Seater Computer Table is available at NTSC, Okhla, New Delhi -110020, Tenderer is option to visit the centre and view the sample before filling the Tender.)</p>	140 Nos.		
B.	Duties and taxes a) VAT @ Any other taxes or charges indicate with rate of tax or cartage etc. b) c) d)			
TOTAL IN FIGURE (A+B)				
TOTAL IN WORDS (A+B): (Value inclusive all)				
The above quoted price should be inclusive of basic price with all Taxes & Duties (as applicable). The price competitiveness of total price shall be given due consideration while analyzing the Commercial Bid. The NTSC will not issue any form toward rebate / exclusion of Sales Tax/VAT etc.				

Signature of the Tenderer,
Name, Designation of the Signatory,
Seal of the Company,
Date:



Undertaking

(On company letter head)

- We declare that we are not a defaulter to any Govt. organization/ PSU since last 2 years from the date of issue of this tender no **NTSC/OK/COMP/TRG/2016-17/29** due to non-supply of material for any reason as agreed to supply in stipulated time.
- We will be liable for any manufacturing defect for a period of 12 months. Within this period product shall be repaired at our own cost. In case of product is not repaired within 5 days, it shall be repaired by NTSC, Okhla, New Delhi-110020 and we shall be liable to compensate total cost.
- We confirm with our acceptance the Instructions to the Tender & Terms & Conditions of Tender.
- We also confirm that this Tender has been thoroughly read while filling up the Tender and all information are true & best of our knowledge.

Signature of the Tenderer,
Name, Designation of the Signatory,
Seal of the Company,
Date:



FOUR SEATER COMPUTER TABLE

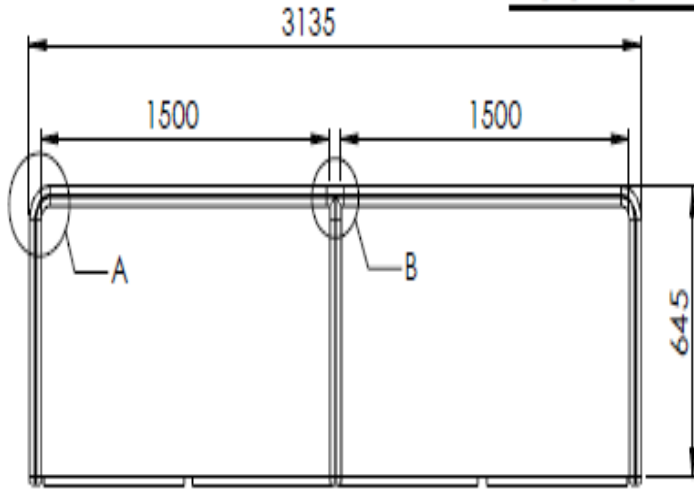

TOP ELEVATION



DETAIL A



DETAIL B

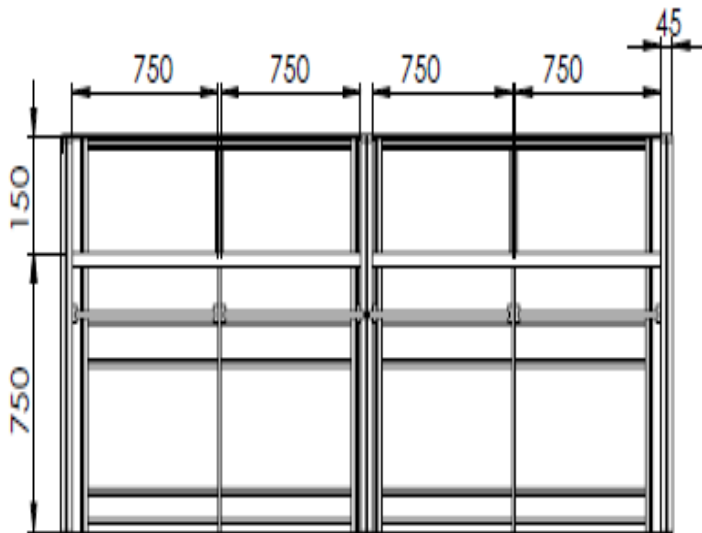

FRONT ELEVATION

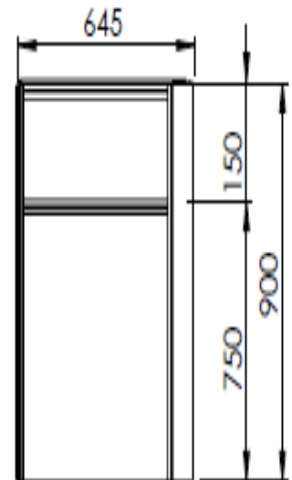

SIDE ELEVATION

Signature of the Tenderer,
Name, Designation of the Signatory,
Seal of the Company,
Date:



FOUR SEATER COMPUTER TABLE

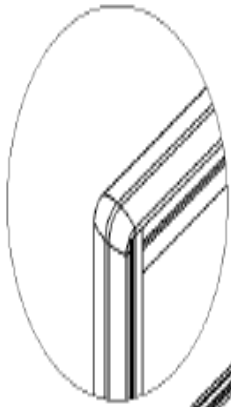

DETAIL A

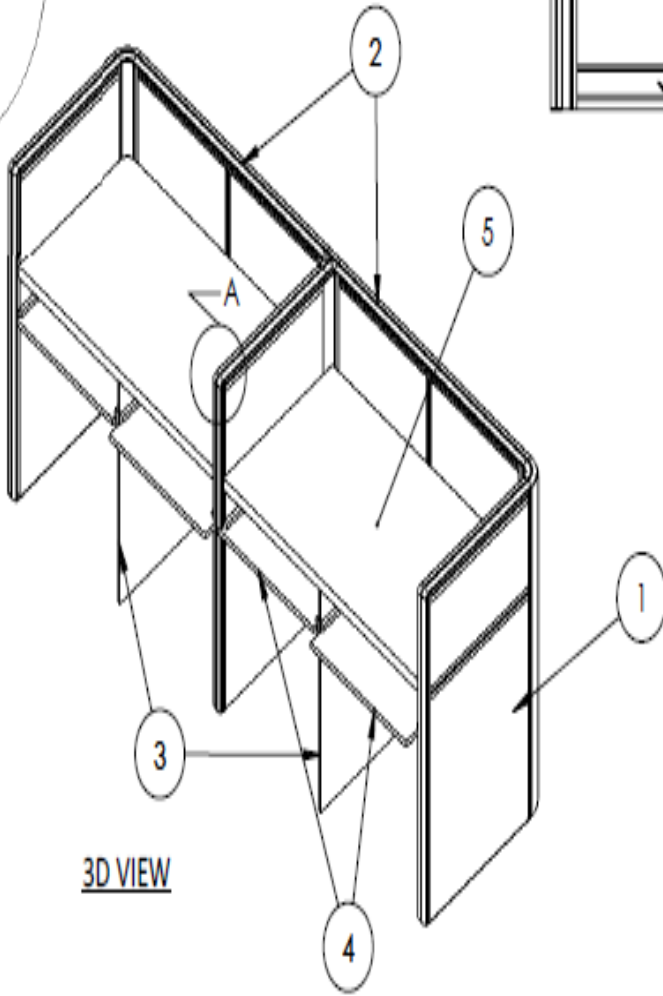

3D VIEW

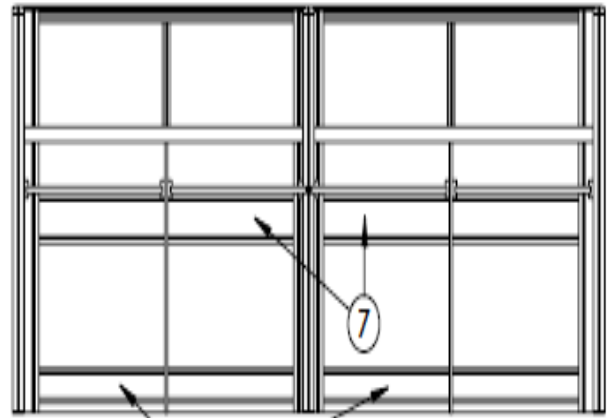

FRONT ELEVATION

S.NO	Specification of Material
1	45 mm Thick partition, Linear Work Station Double Race Way (Aluminum), Pre-laminated Board with 20 gauge Duly powder coated** (50-60 microns).
2	45 mm Thick partition, Front Work Station Double Race Way (Aluminum), Pre-laminated Board with 20 gauge Duly powder coated** (50-60 microns).
3	18 mm Thick gable end (Pre-laminated partition board)
4	4 Nos. key board tray (18 mm thick Pre-laminated partition board with telescopic channel)
5	25 mm thick table top (pre-laminated partition board)
6	Raceway- 1(Aluminum) for electrical connection with 20 gauge Duly powder coated** (50-60 microns).
7	Raceway - 2 (Aluminum) for networking 20 gauge Duly powder coated** (50-60 microns).

Signature of the Tenderer,
 Name, Designation of the Signatory,
 Seal of the Company,
 Date:



SNAPS OF FOUR SEATER COMPUTER TABLE



Signature of the Tenderer,
Name, Designation of the Signatory,
Seal of the Company,
Date:



*****END OF TENDER DOCUMENT*****