

एन.एस.आई.सी.  
**NSIC**  
ISO 9001:2008

# PROSPECTUS

*Training Programmes*

*Build Career  
with Industry*



**The National Small Industries Corporation Ltd.**  
(A Govt of India Enterprise)

**Technical Services Centre**

A-1, Industrial Estate, Aligarh-202 001 (U.P.) India  
Tel./Fax: +91-571-2403552 Phone : 0571-2400364  
E-mail: [ntsecalig@nsic.co.in](mailto:ntsecalig@nsic.co.in) Website: [www.nsic.co.in](http://www.nsic.co.in)

## **NSIC-TSC, ALIGARH AT A GLANCE**

The National Small Industries Corporation Ltd. (NSIC) - technical service Centre was established in the year 1986 primarily for up-liftment of lock & hardware, allied industries and rural artisans.

### **Location**

The NSIC-Technical Services Centre is situated at A-1, Industrial, Estate (Near Exhibition Ground), I.T.I. Road, Aligarh (U.P).

### **How to Reach**

The NSIC-Technical Services Centre is about 2Kms From Railway Station and Bus Stand. The Auto and Cycle Rickshaws are available from Railway Station/Bus stand to reach the Centre.

### **Aims and Objective**

- ❖ To provide technical & vocational training to youths for employment generation.
- ❖ To improve quality and productivity by providing tools and on job training.
- ❖ Up gradation of technology to MSMEs.
- ❖ To provide skilled Manpower to MSMEs.
- ❖ To provide common facility services in the areas such as:

Design and development of press tools, Dies and Moulds, jigs and Fixtures, Gauges, Job work services to MSMEs on Conventional & CNC Machines, Heat treatment facility etc.

### **(A) Training Activities**

NTSC Aligarh has a wide spectrum of Training Courses ranging from Basic Technical Courses to specialized & Hi-TECH Training Courses as well as tailor made courses to suit the needs and requirements of Industries, Also providing vocational training to the Diploma in Engg . /B. Tech & MBA students.

Further NSIC, Aligarh has also been conducted specialized training programs sponsored by various Govt. department/Govt. agencies for the benefit of weaker sections of society.

- ❖ The centre has trained more than 26.000 youths in different industrial trades.
- ❖ We are committed for quality training.
- ❖ We maintain the ethics of teachers and Students relationship.
- ❖ We are more emphasizing on job training along with classroom training.
- ❖ We trained our trainees to get employment and also encourage them for self-employment.

### **Placement Facilities**

The centre is providing placement facilities of passed out trainees in Industries campus interview. About 80% to 90% trainees absorbed by SMEs and Industries through campus interviews.

## (B) Common Facility Services

- ❖ Measuring facility through profile projector.
- ❖ Design on Auto-CAD.
- ❖ Design Development of jigs, fixtures & gauges.
- ❖ Design and development of jigs fixtures & gauges.
- ❖ Re-engineering through 3D-Digitizer.
- ❖ Job work on :
  - Conventional Machines (lathe, Milling, Grinders, Shaper, drilling )
  - Hi-tech Machines (CNC Lathe, CNC Wire cut, VMC & EDM)
- ❖ Heat Treatment, Hardness Testing & Press work.

## Faculties & Staff

01. Deputy general Manager	B.E.(Mech.),PGDBM M.Tech.
02. Manager (Tech.)	Diploma in Mechanical, post Dip. in Plastic Mould
03. Manager (A/c)	B.Com, MFC, CA (Inter)
04. Dy. Manager	B.Com
05. Asst. Manager (Tech)	B.Tech.
06. Asst Manager (Tech)	B.Tech, MBA
07. Development Officer (Tech)	I.T.I. (Tool Design)
08. Master Technician	Electrician Course
09. Development Officer (Tech )	I.T.I & N.T.A in Machinist
10. Tech Gr.I	N.T.A in Machinist
11. Tech Gr.I	Turner
12. Tech Gr.I	Fitter trade Course
13. Draftsman Gr. I	I.T.I.(D/Man),(NTA.D/Man)& tool Design
14. Guest faculty	As and when required the centre is engaging Guest faculty/expert for the specific purposes

## Library and First Aid Facility available

The First Aid and Library facilities are available with various technical as well as social books at this centre for the benefit of our trainees.



## Facilities installed

1) CNC Milling machine/VMC
2) CNC Wire cut machine
3) CNC Lathe Machine
4) EDM
5) NH-26, Lathe machine
6) Universal cylindrical grinding machine
7) Surface grinding Machine
8) Radial drill Machine
9) MITR Milling Machine
10) Universal Milling Machine
11) Horizontal milling Machine
12) Shaper machine
13) Power press 40T Machine
14) Tool & Cutter Grinder
15) Arc Welding machine
16) Heat treatment Furnaces
17) Hardness tester
18) Profile projector
19) Manual Drafting units
20) Computerized accounting facility with NGN & Tally 9.0 Softwares
21) Design lab. Equipments with five computer systems, laser printer, scanner with software of Auto CAD, Del-CAM, PRO-Engineer, Master CAM, NX Tooling
22) Manual Drafting units



<b>NAME OF THE COURSE</b>	<b>Tool &amp; Die Design with Auto CAD</b>
<b>DURATION</b>	<b>2 Years</b>
<b>CAPACITY</b>	<b>10 members</b>
<b>QUALIFICATION</b>	<b>10<sup>th</sup> Passed</b>

**Topics covered under Tool & Die Design with Auto-CAD course:**

**THEORY:**

**(1st Year Syllabus)**

- ❖ **Introduction about Engineering Drawings**
- ❖ **Lines and types**
- ❖ **Symbols**
- ❖ **Lettering**
- ❖ **Projection**
- ❖ **1<sup>st</sup> Angle & 3<sup>rd</sup> Angle**
- ❖ **Isomeric views**
- ❖ **Orthographic views. Press tool design**
- ❖ **Dimension Techniques**
- ❖ **Open Assembly Drawings**
- ❖ **Computer Awareness**
- ❖ **Basics of computer and CAD**
- ❖ **How to make 2d drawings in Auto CAD**
- ❖ **How to make 3d models in auto CAD**
- ❖ **How to edit and modify drawings in Auto CAD**
- ❖ **Hatching utilities create and edit**

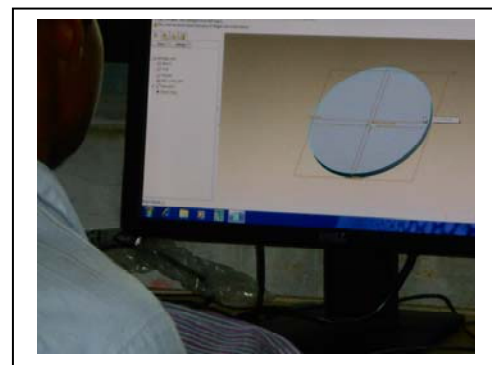

- ❖ Advanced objects creations and editing
- ❖ How to dimensions entitles
- ❖ How to create and assess symbols
- ❖ How to prepare and manage a layout
- ❖ How to print drawings and 3d models

**(2<sup>nd</sup> Year Syllabus)**

- ❖ Introduction to tool design
- ❖ Awareness with Tool Room m/c & Safety.
- ❖ Designing Concepts & Designing Parameters.
- ❖ Press Tool Designing
- ❖ Material Selection
- ❖ Limits, Fits, Tolerances
- ❖ Explain about measurement
- ❖ Awareness of measuring instruments
- ❖ Measurement on Profile Projector
- ❖ Awareness of mould Design
- ❖ Compound Die
- ❖ Machining Process
- ❖ Awareness of jigs & Fixtures
- ❖ Inspection & Quality Improvement Techniques
- ❖ Re-Engineering through 3D Digitizer (Micro scriber)

**PRACTICALS:**

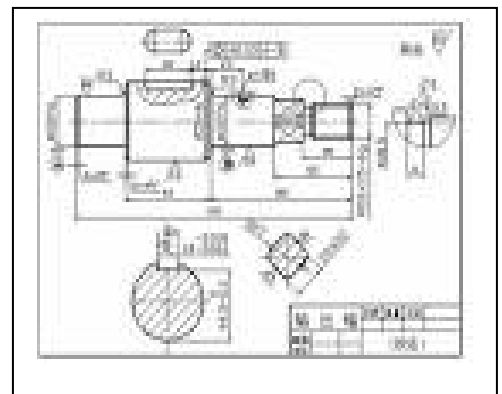

<b>NAME OF THE COURSE</b>	<b>Turner with CNC Lathe</b>
<b>DURATION</b>	<b>2 Years</b>
<b>CAPACITY</b>	<b>10 members</b>
<b>QUALIFICATION</b>	<b>10<sup>th</sup> Passed</b>

**Topics covered under Turner with CNC Lathe course:**

**THEORY:**

**(1st Year Syllabus)**

- ❖ Introduction
- ❖ Industrial Safety and precaution
- ❖ Hand tools
- ❖ Filing work
- ❖ Bench vices and machine vices
- ❖ Metals- Ferrous and Non-Ferrous, Selection of metals
- ❖ Engineering Drawings
- ❖ Workshop calculation
- ❖ Measurement and measuring instruments

**2<sup>nd</sup> Year Syllabus**

- ❖ Introduction to CNC Lathe M/c.
- ❖ Revision of Engg. Drawings .
- ❖ Co-ordinate Geometry.
- ❖ Computer awareness.
- ❖ Introduction to CNC system.
- ❖ Advantage of CNC.



- ❖ Introduction to programming Method.
- ❖ Types of programming.
- ❖ Programming of 'G' Code.
- ❖ Programming of other additional codes.
- ❖ Heat treatment Awareness.
- ❖ Jigs, Fixtures and gauges, Limits, Fits and Tolerances.
- ❖ Manufacturing process and production management.
- ❖ Inspection & quality improvement techniques.
- ❖ Project work.

## **INTRODUCTION**

**Computer added Manufacturing (CAM) encompasses the entire range of product development and manufacturing activities with all the functions being carried out with the help of dedicated software packages. The data required for various functions are passed from one application software to another in a seamless manner. For example, the product data is created during design. This data has to be transferred from the modeling software to manufacturing software without any loss of data. CAM uses a common database wherever feasible and communication technologies to integrate design, manufacturing and associated business functions that combine the automated segments of a factory or a manufacturing facility.**

**CAM has several software tools to address the above needs. Manufacturing engineers are required to achieve the following objectives to be competitive in a global context.**

- Reduction in inventory
- Lower the cost of the product
- Reduce waste
- Improve quality
- Increase flexibility in manufacturing to achieve immediate and rapid response to:
- Product changes
- Production changes
- challenges to the Process change
- Equipment change, Change of personnel

<b>NAME OF THE COURSE</b>	<b>Machinist With CNC Milling/ VMC</b>
<b>DURATION</b>	<b>2 Years</b>
<b>CAPACITY</b>	<b>10 members</b>
<b>QUALIFICATION</b>	<b>10<sup>th</sup> Passed</b>

**Topics covered under Machinist With CNC Milling/ VMC course:**

**THEORY:**

(1st Year Syllabus)

- ❖ Introduction
- ❖ Industrial Safety and precaution
- ❖ Hand tools
- ❖ Filing work
- ❖ Bench vices and machine vices
- ❖ Metals-Ferrous and Non- Ferrous, Selection of metals
- ❖ Engineering drawings
- ❖ Workshop calculation
- ❖ Measurement and measuring instruments
- ❖ Trends in machine tools
- ❖ Shaper machine and shaping operations
- ❖ Milling machine and milling operations
- ❖ Milling accessories and attachments
- ❖ Types of milling cutter & selection of cutters
- ❖ Grinding operations and types of grinding m/c
- ❖ Selection of Grinding wheels
- ❖ Awareness about CNC and EDM machines



## 2<sup>nd</sup> Year Syllabus

- ❖ Introduction to programming Method.
- ❖ Types of programming.
- ❖ Programming of “G” codes.
- ❖ Programming of other additional codes.
- ❖ Details of button of control unit.
- ❖ Setting of the job on machine.
- ❖ Setting of the tool for reference.
- ❖ Program transfer M/c to PC and PC to M/c.
- ❖ Practice on exercise programming as well as machining.
- ❖ Heat Treatment Awareness.
- ❖ Jigs, Fixtures and gauges, Limits, Fits and Tolerances.
- ❖ Manufacturing process and production management.
- ❖ Inspection & quality improvement techniques.
- ❖ Project work

### PRACTICALS:



<b>NAME OF THE COURSE</b>	<b>Tool &amp; Die Maker with CNC Wire-Cut</b>
<b>DURATION</b>	<b>2 Years</b>
<b>CAPACITY</b>	<b>10 members</b>
<b>QUALIFICATION</b>	<b>10<sup>th</sup> Passed</b>

**Topics covered under Tool & Die Maker with CNC Wire-Cut course:**

**THEORY:**

(1st Year Syllabus)

- ❖ Introduction
- ❖ Industrial Safety and precaution.
- ❖ Hand tools.
- ❖ Filing work.
- ❖ Bench vices and machine vices.
- ❖ Metals –Ferrous and Non-Ferrous, Selection of metals.
- ❖ Engineering Drawings.
- ❖ Workshop calculation.
- ❖ Measurement and measuring instruments.
- ❖ Trends in machine tools.
- ❖ Shaper machine and shaping operations.
- ❖ Milling machine and milling operations.
- ❖ Milling accessories and attachments.
- ❖ Types of milling cutters & SELECTION OF CUTTERS
- ❖ Grinding operations and type of grinding m/c
- ❖ Selection of Grinding wheels.
- ❖ Familiarization about tools & Dies, Moulds.



- ❖ Press tools-Blanking, Piercing, Bending and Forming
  - ❖ Dies for pressure Die Casting.
  - ❖ Zinc Die Casting.
  - ❖ Forging Dies.
  - ❖ Dies & Tools Manufacturing Process.
  - ❖ Assembly Practices.
  - ❖ Test & trial of dies and moulds.
  - ❖ Industrial Visit.
- 2<sup>nd</sup> Year Syllabus**



- ❖ Introduction of Machine tools, CNC wire cut EDM m/c and computer basics.
- ❖ Machine Tool Specification with importance.
- ❖ Programming system on computer ELAPT and Auto CAD.
- ❖ X-Y , CO\_ ordinate system, Key Board operation & specified programming Key.
- ❖ Wire drive mechanism with wire material and used as and when required.
- ❖ Dielectric Fluid Flow with effects of conductivity.
- ❖ Environmental conditions and safety precautions.
- ❖ Machining control unit and NC controller.
- ❖ Placement of job on table with vertical alignment of wire electrode.
- ❖ Machining procedure: wire threading, wire tension and wire feed rate, work piece mounting, wire positioning method, select m/c Flushing parameters.
- ❖ Programming in MDI (Manual Data Input).
- ❖ Storing and Loading of program through Floppy.
- ❖ Do's and Don'ts of NC Controller.
- ❖ Machining parameters and use of charts and tables.
- ❖ Precaution of periodically maintenance of m/c and troubleshooting.
- ❖ Heat –treatment awareness.
- ❖ Manufacturing process and production management.
- ❖ Inspection & quality improvement techniques.
- ❖ Project work and production work

<b>NAME OF THE COURSE</b>	<b>Fitter with CNC Wire-Cut</b>
<b>DURATION</b>	<b>2 Years</b>
<b>CAPACITY</b>	<b>10 members</b>
<b>QUALIFICATION</b>	<b>10<sup>th</sup> Passed</b>

### **Topics covered under Fitter with CNC Wire-Cut course:**

#### **THEORY:**

**(1st Year Syllabus)**

- ❖ Introduction
- ❖ Industrial Safety and precaution.
- ❖ Hand tools.
- ❖ Filing work.
- ❖ Bench vices and machine vices.
- ❖ Metals –Ferrous and Non-Ferrous, Selection of metals.
- ❖ Engineering Drawings.
- ❖ Workshop calculation.
- ❖ Measurement and measuring instruments.
- ❖ Trends in machine tools.
- ❖ Shaper machine and shaping operations.
- ❖ Milling machine and milling operations.
- ❖ Milling accessories and attachments.
- ❖ Types of milling cutters & SELECTION OF CUTTERS
- ❖ Grinding operations and type of grinding m/c
- ❖ Selection of Grinding wheels.
- ❖ Familiarization about tools & Dies, Moulds.
- ❖ Press tools-Blanking, Piercing, Bending and Forming
- ❖ Dies for pressure Die Casting.  
Zinc Die Casting.
- ❖ Forging Dies.
- ❖ Dies & Tools Manufacturing Process.



- ❖ **Assembly Practices.**
- ❖ **Test & trial of dies and moulds.**
- ❖ **Industrial Visit.**
- 2<sup>nd</sup> Year Syllabus**
- ❖ **Introduction of Machine tools , CNC wire cut EDM m/c and computer basics.**
- ❖ **Machine Tool Specification with importance.**
- ❖ **Programming system on computer ELAPT and Auto CAD.**
- ❖ **X-Y , CO\_ ordinate system, Key Board operation & specified programming Key.**
- ❖ **Wire drive mechanism with wire material and used as and when required.**
- ❖ **Dielectric Fluid Flow with effects of conductivity.**
- ❖ **Environmental conditions and safety precautions.**
- ❖ **Machining control unit and NC controller.**
- ❖ **Placement of job on table with vertical alignment of wire electrode.**
- ❖ **Machining procedure: wire threading, wire tension and wire feed rate, work piece mounting, wire positioning method, select m/c Flushing parameters.**
- ❖ **Programming in MDI (Manual Data Input).**
- ❖ **Storing and Loading of programme through Floppy.**
- ❖ **Do's and Don'ts of NC Controller.**
- ❖ **Machining parameters and use of charts and tables.**
- ❖ **Precaution of periodically maintenance of m/c and troubleshooting.**
- ❖ **Heat –treatment awareness.**
- ❖ **Manufacturing process and production management.**
- ❖ **Inspection & quality improvement techniques.**
- ❖ **Project work and production work**

<b>NAME OF THE COURSE</b>	<b>Draughtsman (Mechanical) with Auto CAD</b>
<b>DURATION</b>	<b>1 Year</b>
<b>CAPACITY</b>	<b>10 members</b>
<b>QUALIFICATION</b>	<b>10<sup>th</sup> Passed</b>

**Topics covered under Draughtsman (Mechanical) with Auto CAD course:**

**THEORY:**

- ❖ Introduction about Engg. Drawings
- ❖ Engg. Lines and types
- ❖ Symbols
- ❖ Lettering
- ❖ Projection
- ❖ 1th Angle & 3th Angle
- ❖ Isomeric views
- ❖ Orthographic views .
- ❖ Dimension Techniques
- ❖ Assembly Drawings
- ❖ Work shop calculation
- ❖ Introduction to Tool Design
- ❖ Awareness with Tool room m/c & Safety
- ❖ Designing concept & design parameters
- ❖ Press Tool Design
- ❖ Material selection
- ❖ Limits, Fits, Tolerances

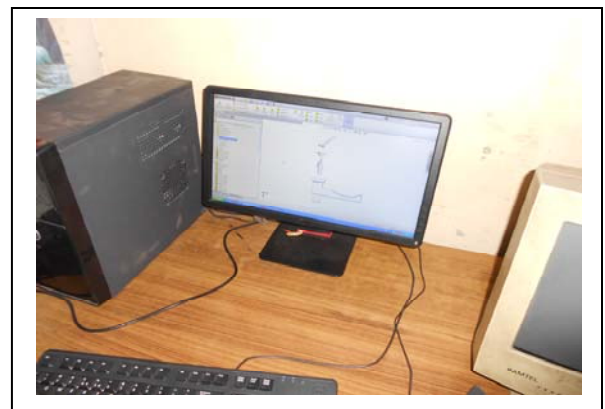

- ❖ Explain about measurement
- ❖ Awareness of measuring instruments
- ❖ Awareness of mould design
- ❖ Compound Die
- ❖ Machining process
- ❖ Awareness with Jigs & Fixtures
- ❖ Inspection & Quality Improvement Techniques
- ❖ Auto-CAD

**PRACTICALS:**



<b>NAME OF THE COURSE</b>	<b>Machinist</b>
<b>DURATION</b>	<b>1 Year</b>
<b>CAPACITY</b>	<b>10 members</b>
<b>QUALIFICATION</b>	<b>10<sup>th</sup> Passed</b>

**Topics covered under Machinist course:**

**THEORY:**

- ❖ Introduction
- ❖ Industrial Safety and precaution
- ❖ Hand tools
- ❖ Filing work
- ❖ Bench vices and machine vices
- ❖ Metals-Ferrous and Non- Ferrous, Selection of metals
- ❖ Engineering Drawings
- ❖ Workshop calculation
- ❖ Measurement and measuring instruments
- ❖ Trends in machine tools
- ❖ Shaper machine and shaping operations
- ❖ Milling machine and Milling operations
- ❖ Milling accessories and attachments
- ❖ Type of milling cutters & selection of cutters
- ❖ Grinding operations and type of grinding m/c
- ❖ Selection of Grinding wheels
- ❖ Awareness about CNC and EDM machines
- ❖ Quality Control and Up gradation



## PRACTICALS:

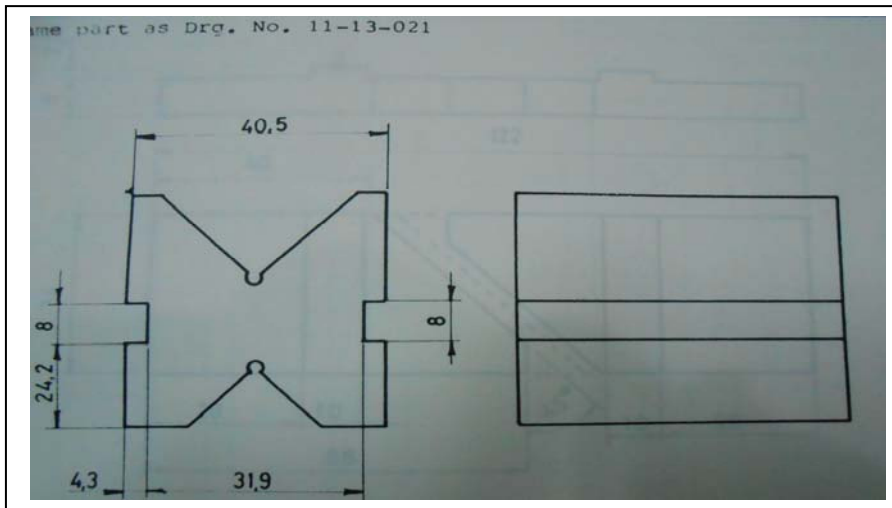

Sr. no.	Operations	Tools & Measuring Instruments
1.	Prepare the machine and the work place.	1. Side and face cutter $\phi 80 \times 1'' \times 8$
2.	Clamp the job in the vice.	2. Vernier Caliper.
3.	Fix face and side cutter.	
4.	Set the cutter in position	
5.	Mill the slots $8 \times 4.3$ .	

<b>NAME OF THE COURSE</b>	<b>Fitter</b>
<b>DURATION</b>	<b>1 Year</b>
<b>CAPACITY</b>	<b>10 members</b>
<b>QUALIFICATION</b>	<b>10<sup>th</sup> Passed</b>

### **Topics covered under Fitter course:**

#### **THEORY:**

- ❖ Introduction
- ❖ Industrial Safety and Precaution
- ❖ Hand tools
- ❖ Filing work
- ❖ Bench vices and machine vices
- ❖ Metals-Ferrous & Non-Ferrous, Selection of metals
- ❖ Engineering Drawings
- ❖ Workshop calculation.
- ❖ Measurement and measuring
- ❖ Limits, Fits, tolerances
- ❖ Trends in machine tools
- ❖ Drilling Operations and Radial Drill machine.
- ❖ Shaper machine and shaping operations.
- ❖ Milling machine and Milling operations.
- ❖ Milling accessories and attachments.
- ❖ Types of milling cutters & selection of cutters.
- ❖ Grinding operations and type of Dies, Moulds.
- ❖ Selection of Grinding wheels.

- ❖ Familiarization about tools & Dies, Moulds.
- ❖ Press Tools-Blanking Piercing, Bending & Forming.
- ❖ Dies and Tools Manufacturing Process.
- ❖ Jigs, Fixtures & gauges.
- ❖ Production Management.
- ❖ Assembly Practices.
- ❖ Test and Trial of dies and moulds

**PRACTICALS:**

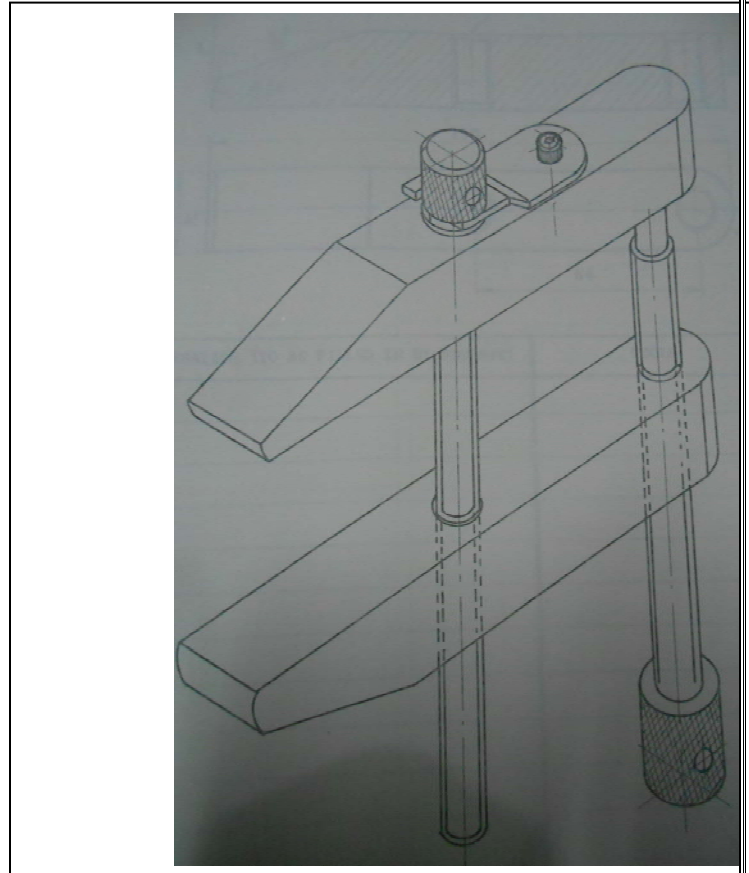

<b>NAME OF THE COURSE</b>	<b>Mechanical Maintenance Fitter (MMF)</b>
<b>DURATION</b>	<b>1 Year</b>
<b>CAPACITY</b>	<b>10 members</b>
<b>QUALIFICATION</b>	<b>10<sup>th</sup> Passed</b>

**Topics covered under Mechanical Maintenance Fitter (MMF) course:**

**THEORY:**

- ❖ Introduction.
- ❖ Industrial safety and precautions.
- ❖ Drill and Radial Drill Machine.
- ❖ Metals and their selection of fits.
- ❖ Fitting work and types of fits.
- ❖ Limits Fits, Tolerances.
- ❖ Jigs, Fixtures & Gauges.
- ❖ Measuring instruments and their use.
- ❖ Engineering Drawings.
- ❖ Assembly and Re-Assembly of equipments
- ❖ Maintenance procedure.
- ❖ Breakdown maintenance.
- ❖ Preventive maintenance.
- ❖ Machine tools maintenance.
- ❖ Press tools and their repairs.
- ❖ Mechanical, Hydraulic and pneumatic systems and circuit diagrams.
- ❖ Study of various machine tools.
- ❖ Practice on shop floor/on job training



<b>NAME OF THE COURSE</b>	<b>Turner</b>
<b>DURATION</b>	<b>1 Year</b>
<b>CAPACITY</b>	<b>10 members</b>
<b>QUALIFICATION</b>	<b>10<sup>th</sup> Passed</b>

**Topics covered under Turner course:**

**THEORY:**

- ❖ Introduction.
- ❖ Industrial Safety and precaution.
- ❖ Hand tools.
- ❖ Filing work.
- ❖ Bench Vices and machine vices.
- ❖ Metals-Ferrous and Non-Ferrous, Selection of Metals.
- ❖ Engineering Drawings
- ❖ Workshop calculation.
- ❖ Measurement and measuring instruments.
- ❖ Trends in machine tools
- ❖ Lathe machine and its parts.
- ❖ Lathe machine operations.
- ❖ Lathe accessories and attachments.
- ❖ Types of lathes.
- ❖ Single Point Cutting Tools and Multi Cutters.
- ❖ Selection of drills and taps for Threading.
- ❖ Types of threads.



**PRACTICALS:**

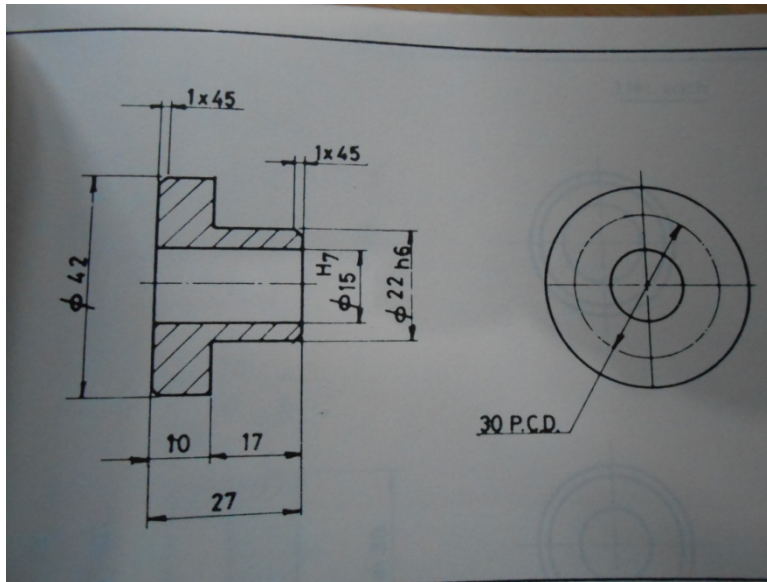

Sr. no.	Operations	Tools & Measuring Instruments
1.	Hold the jobs in 3 –Jaw Chuck protruding 30 mm.	1. Facing tool .
2.	Rough $\square$ 22.5X16.5 & 42.5	2. Knife tool.
3.	Make centre.	3. Boring tool.
4.	Drill through with 10 & $\square$ 14	4. Vernier Caliper.
5.	Rough & Finish the bore.	5. Micrometer 0-25.
6.	Finish $\square$ 28 h6 x 17 and $\square$ 42 .	6. Inside micrometer 5-25.
7.	Give Chamfer.	7. Set of drills.
8.	Reverse the job and face to correct length	
9.	Give chamfer.	
10.	Mark the P.C.D.	

<b>NAME OF THE COURSE</b>	<b>Tool and Die Maker</b>
<b>DURATION</b>	<b>1 Year</b>
<b>CAPACITY</b>	<b>10 members</b>
<b>QUALIFICATION</b>	<b>10<sup>th</sup> Passed</b>

**Topics covered under Tool and Die Maker course:**

**THEORY**

- ❖ Introduction
- ❖ Industrial Safety and precaution
- ❖ Hand Tools
- ❖ Bench vices and machine Vices.
- ❖ Filing works and Types of files
- ❖ Engineering Drawings
- ❖ Workshop calculation
- ❖ Measurements and measuring instruments
- ❖ Drilling and Types of Drill Machine
- ❖ Milling machine and its operations
- ❖ Lathe and lathe operations Press Tools.
- ❖ Fits, Limits, Tolerances
- ❖ Familiarization about tools & Dies
- ❖ Press Tools-Banking, piercing, Bending & Forming
- ❖ Knowledge of Material
- ❖ Dies for Pressure Die Casting
- ❖ Zinc Die Casting



- ❖ Forging Dies
- ❖ Dies and Tools Manufacturing Process.
- ❖ Assembly Practices.
- ❖ Inspection & Quality Control
- ❖ Test and Trial

**PRACTICALS:**

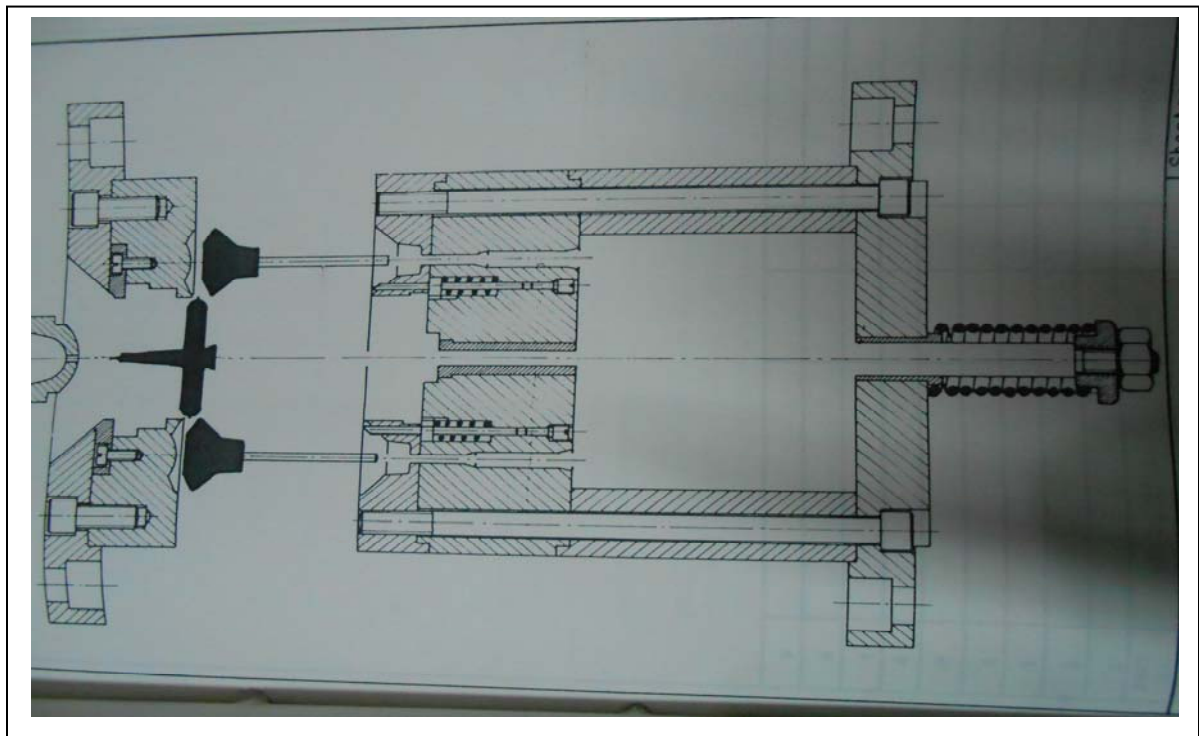

<b>NAME OF THE COURSE</b>	<b>Inspection &amp; Quality Control</b>
<b>DURATION</b>	<b>1 Year</b>
<b>CAPACITY</b>	<b>10 members</b>
<b>QUALIFICATION</b>	<b>10<sup>th</sup> Passed</b>

**Topics covered under Inspection & Quality Control course:**

**THEORY:**

- ❖ Introduction
- ❖ Industrial Safety and Precautions
- ❖ Definition and vocabulary
- ❖ Hand Tools
- ❖ Bench vices and Machine vices
- ❖ Filing works and types of files
- ❖ Engineering Drawings
- ❖ Workshop calculation
- ❖ Measurement and measuring instruments
- ❖ Drilling and Types of Drill machine
- ❖ Milling machine and its operations
- ❖ Lathe and Lathe operations Press Tools
- ❖ Fits , Limits, Tolerances.
- ❖ Familiarization about tools & Dies
- ❖ Knowledge of Material.
- ❖ Production management & Manufacturing process
- ❖ Role of Inspector in Industries



- ❖ **Types of Inspection**
- ❖ **Incoming Raw material Inspection**
- ❖ **Stage Inspection**
- ❖ **Final Inspection**
- ❖ **Role of Quality Circle**
- ❖ **Precision and Accuracy**
- ❖ **Quality Control and Quality Assurance.**
- ❖ **Tables, Charts and Graphs.**
- ❖ **Practice on shop floor**



**PRACTICALS:**

<b>NAME OF THE COURSE</b>	<b>Electrician</b>
<b>DURATION</b>	<b>1 Year</b>
<b>CAPACITY</b>	<b>10 members</b>
<b>QUALIFICATION</b>	<b>10th Passed</b>

### **Topics covered under Electrician course:**

#### **THEORY:**

- ❖ Introduction.
- ❖ Industrial Safety and Precaution..
- ❖ Sign and Symbol.
- ❖ Basic Electric- Definition of Voltage,
- ❖ Current, EMF & Resistance.
- ❖ Ohm's law, Work, Energy and power.
- ❖ Resistance law-Series & Parallel connections.
- ❖ Conductors and Non- conductors.
- ❖ Capacitor and Inductor.
- ❖ Electrolysis.
- ❖ Magnet and Electro- Magnet
- ❖ A.C. Circuit, Lagging & Leading power factor
- ❖ A.C. Power, disadvantages of low factor.
- ❖ Alternator, Transformer, Regulation, Efficiency.
- ❖ Single phase and three phase motors.
- ❖ Capacitor Motor (Theory and Practical)
- ❖ Repulsion Motor (Theory and Practical)



<b>NAME OF THE COURSE</b>	<b>Programming and Operation of Wire-Cut</b>
<b>DURATION</b>	<b>6 Months</b>
<b>CAPACITY</b>	<b>20 members</b>
<b>QUALIFICATION</b>	<b>12<sup>th</sup> Passed</b>

**Topics covered under Programming and Operation of Wire-Cut course:**

**THEORY:**

- ❖ Introduction
- ❖ Industrial Safety and precaution
- ❖ Hand Tools
- ❖ Bench vices and machine vices.
- ❖ Metals-Ferrous and Non-Ferrous, Selection of metals
- ❖ Engineering Drawings
- ❖ Workshop calculation
- ❖ Measurement and measuring instruments
- ❖ Trends in machine tools
- ❖ Milling machine and milling operations
- ❖ Milling accessories and attachments
- ❖ Types of milling cutters & selection of cutters
- ❖ Grinding and types of grinding m/c
- ❖ Awareness about CNC and EDM machine
- ❖ Co-ordinate geometry
- ❖ Introduction to CNC System
- ❖ Computer Awareness.
- ❖ Machine Tool Specification with Importance
- ❖ Programming system on computer-ELAPT and Auto CAD

- ❖ **X-Y, Co-ordinate system Key-board operation & Specified programming key**
- ❖ **Wire drive mechanism with wire material and used as and when required**
- ❖ **Dielectric fluid flow with effects of conductivity**
- ❖ **Environmental conditions and safety Precautions**
- ❖ **Machining control unit and NC controller**
- ❖ **Placement of job on table with vertical Alignment of wire electrode.**
- ❖ **Machining procedure :wire threading, wire tension and wire fed rate, work piece mounting, wire Positioning method, select m/c /flushing parameters**
- ❖ **Storing and loading of programme through floppy**
- ❖ **DO's and Don'ts of NC controller**
- ❖ **Machining parameters and use of charts and tables**
- ❖ **Precaution of periodically maintenance of Machine and trouble shooting.**

**PRACTICALS:**

<b>NAME OF THE COURSE</b>	<b>Programming and operation of CNC Lathe</b>
<b>DURATION</b>	<b>6 Months</b>
<b>CAPACITY</b>	<b>20 members</b>
<b>QUALIFICATION</b>	<b>12<sup>th</sup> Passed</b>

## **Topics covered under Programming and operation of CNC Lathe course:**

### **THEORY:**

- ❖ Introduction
- ❖ Industrial Safety and precautions
- ❖ Hand tools.
- ❖ Bench vices and machine vices.
- ❖ Metal-ferrous and Non-ferrous
- ❖ selection of metals.
- ❖ Engineering drawing.
- ❖ Workshop calculation.
- ❖ measurement and measuring
- ❖ Trends in machine tools.
- ❖ Milling machine and milling operations..
- ❖ Milling accessories and attachments.
- ❖ Types of milling cutters & selection of cutters.
- ❖ Grinding operations and type of grinding Machine.
- ❖ Awareness about CNC and EDM machines.
- ❖ Introduction to CNC Lathe M/c
- ❖ Revision of Engg. Drawings.
- ❖ Co- ordinate Geometry.
- ❖ Computer awareness.
- ❖ Introduction to CNC- System.
- ❖ Advantage of CNC.



- ❖ Introduction to programming.
- ❖ Types of programming.
- ❖ Programming of 'G' Codes.
- ❖ Programming of other additional Codes.
- ❖ Details of Button of control unit.
- ❖ Setting of the job on Machine.
- ❖ Setting of tool for reference.
- ❖ Program Transfer M/c to PC and PC to M/c.
- ❖ Practice on exercise programming as well as machining.
- ❖ Heat treatment Awareness.
- ❖ Tigs, fixtures and gauges, Limits, Fits and Tolerances.
- ❖ Manufacturing Process and production Management.
- ❖ Inspection & quality improvement techniques.
- ❖ Project work.

**PRACTICALS:**

<b>NAME OF THE COURSE</b>	<b>Programming and Operation of CNC Milling/VMC</b>
<b>DURATION</b>	<b>6 Months</b>
<b>CAPACITY</b>	<b>20 members</b>
<b>QUALIFICATION</b>	<b>12<sup>th</sup> Passed</b>

## **Topics covered under Programming and Operation of CNC/VMC course:**

### **THEORY:**

- ❖ Introduction
- ❖ Industrial Safety and precaution
- ❖ Hand tools.
- ❖ Bench vices and machine vices
- ❖ Metals-Ferrous and Non-Ferrous, Selection of
- ❖ Engineering Drawings.
- ❖ Workshop calculation.
- ❖ Measurement and measuring instruments
- ❖ Trends in machine tools.
- ❖ Milling machine and milling operations
- ❖ Milling accessories and attachments
- ❖ Types of milling cutters & selection of cutters
- ❖ Grinding operations and type of grinding M/c.
- ❖ Awareness about CNC and END machines.
- ❖ Introduction to Milling M/c
- ❖ Revision of Engg. Drawings.
- ❖ Co-ordinate Geometry.
- ❖ Introduction to CNC-System
- ❖ Advantage of CNC.
- ❖ Introduction to programming method.



- ❖ Types of programming.
- ❖ Programming of “G” Codes.
- ❖ Programming of other additional Codes.
- ❖ Details of Button of control unit.
- ❖ Setting of the job on Machine.
- ❖ Setting of tool for Reference.
- ❖ Operating method of Machine.
- ❖ Program Transfer M/c to PC and PC
- ❖ Practice on Exercise Programming as well as Machining.

**PRACTICALS:**



Sr. no.	Operations	Tools & Measuring Instruments
1.	Prepare Program for above Die	Solid carbide End Mill Cutter Dia 12.0
2.	Transfer Program by Flash Card	Dial Indicator
3.	Clamp the job on the bed	Vernier Calliper
4.	Clamp the tool on the Machine Spindle	
5.	Dial the job	
6.	Taken the reference for X,Y, & Z Axis	
7.	Run the machine to cut the Cavity	
8.	Check the die as per Drawing	
9.		
10.		

<b>NAME OF THE COURSE</b>	<b>CNC Wire-Cut Programming and Operation</b>
<b>DURATION</b>	<b>3 Months</b>
<b>CAPACITY</b>	<b>10 members</b>
<b>QUALIFICATION</b>	<b>ITI/Dip. Engg. /BE</b>

**Topics covered under CNC Wire-Cut Programming and Operation course:**

**THEORY:**

- ❖ Introduction of Machine tools, CNC EDM wire Cut M/c and computer basics.
- ❖ Industrial Safety and precautions.
- ❖ Machine Tool Specification with importance.
- ❖ Programming system on computer –ELAPT and Auto CAD.
- ❖ X-Y, Co-ordinate System Key-board operation & Specified programming Key.
- ❖ Wire drive mechanism with wire material and used as and when required.
- ❖ Dielectric Fluid Flow with effects of conductivity.
- ❖ Environmental conditions and Safety precautions.
- ❖ Machining control unit and NC controller.
- ❖ Placement of job on table with vertical alignment of wire electrode.
- ❖ Machining procedure: wire threading, wire tension and wire Feed rate ,work piece mounting , wire positing method, select m/c/Flushing parameters.
- ❖ Programming in MDI (Manual Data Input).
- ❖ Storing and Loading of program through Floppy.
- ❖ Do's and Don'ts of NC controller.
- ❖ Machining parameters and use of charts and tables.
- ❖ Precaution of periodically maintenance of Machine and trouble shooting.

**PRACTICALS:**

<b>NAME OF THE COURSE</b>	<b>Programming and Operation of CNC Milling/VMC</b>
<b>DURATION</b>	<b>3 Months</b>
<b>CAPACITY</b>	<b>10 members</b>
<b>QUALIFICATION</b>	<b>ITI/Dip. Engg. /BE</b>

**Topics covered under Programming and Operation of CNC Milling/ VMC course:**

**THEORY:**

- ❖ Introduction to Milling M/c
- ❖ Revision of Engg Drawings.
- ❖ Co-ordinate Geometry.
- ❖ Introduction to CNC-System.
- ❖ Advantage of CNC
- ❖ Introduction to programming method
- ❖ Types of programming.
- ❖ Programming of 'G' Codes.
- ❖ Programming of other additional Codes
- ❖ Details of Button of control unit
- ❖ Setting of the Job on Machine.
- ❖ Setting of tool for Reference
- ❖ Operating method of Machine
- ❖ Program Transfer M/c to PC and PC to M/c
- ❖ Practice on Exercise Programming as well as Machining.

**PRACTICALS:**

<b>NAME OF THE COURSE</b>	<b>Programming and Operation of CNC Lathe</b>
<b>DURATION</b>	<b>3 Months</b>
<b>CAPACITY</b>	<b>10 members</b>
<b>QUALIFICATION</b>	<b>ITI/Dip. Engg. /BE</b>

**Topics covered under Programming and Operation of CNC Lathe course:**

**THEORY:**

- ❖ Introduction to CNC Lathe M/c.
- ❖ Revision of Engg. Drawings.
- ❖ Co-ordinate Geometry.
- ❖ Computer awareness.
- ❖ Introduction to CNC-System.
- ❖ Advantage of CNC.
- ❖ Introduction to programming method.
- ❖ Types of Programming .
- ❖ Programming of 'G' Codes.
- ❖ Programming of other additional Codes.
- ❖ Details of Button of control unit.
- ❖ Setting of the Job on Machine.
- ❖ Setting of tool for reference .
- ❖ Program Transfer M/c to PC and PC to M/c.
- ❖ Practice on Exercise Programming as well as Machining.
- ❖ Heat treatment Awareness.
- ❖ Jigs, Fixtures and gauges, Limits, Fits and Tolerances.
- ❖ Manufacturing process and production Management.
- ❖ Inspection & quantity improvement techniques.
- ❖ Project work.



<b>NAME OF THE COURSE</b>	<b>Computer Operation &amp; Programming Assistance</b>
<b>DURATION</b>	<b>1 Year</b>
<b>CAPACITY</b>	<b>10 members</b>
<b>QUALIFICATION</b>	<b>10<sup>th</sup> Passed</b>

## **Topics covered under- Computer Operation & Programming Assistance course:**

### **THEORY:**

#### **Basic Computer Concepts**

- ❖ Introduction.
- ❖ Working with Computer's
- ❖ Computer Tools & Utilities.
- ❖ 4 Computer Terminologies
- ❖ Software and Hardware
- ❖ Hardware Accessories
- ❖ Manipulating file & Folders
- ❖ Software Application
- ❖ Working with the windows environments
- ❖ Operating System software
- ❖ Introduction to Internet
- ❖ Types of Networks
- ❖ Internet Architecture
- ❖ Computer Topologies
- ❖ IP, HTTP, WWW,
- ❖ Domains, Web pages
- ❖ Email Id, online Transaction.



#### **M.S. Word**

- ❖ Introduction.

- ❖ Working with Documents.
- ❖ Editing Text Documents.
- ❖ Formatting Documents.
- ❖ Setting Paragraph style.
- ❖ Setting Document styles.
- ❖ Setting Documents styles.
- ❖ Drawing Tools.
- ❖ Tools
- ❖ Printing Documents.

#### M.S. Excel

- ❖ Introduction
- ❖ Working with Documents.
- ❖ Formatting Spreadsheets.
- ❖ Working with Sheets.
- ❖ Working with Sheets.
- ❖ Creating Charts.
- ❖ Using Tools.
- ❖ Computer Entering and Editing data.
- ❖ Sheets. Formatting & Style Background, Colour, Borders, & shading.
- ❖ Printing work Sheets.

#### M.S. Power point

- ❖ Introduction.
- ❖ Creating a Presentation.
- ❖ Formatting a Presentation.
- ❖ Adding Graphics to the presentation.
- ❖ Adding effects to the presentation.
- ❖ Setting presentation styles.
- ❖ Inserting Pictures, movies, tables, etc. Into the presentation.
- ❖ Opening New Presentation.
- ❖ Printing Handouts.
- ❖ Generating Standalone Presentation viewer.

#### M.S. Access

- ❖ Introduction.
- ❖ Opening & Saving Database Files

- ❖ **Creating Queries.**
- ❖ **Creating Forms**
- ❖ **Creating & Printing reports.**

#### **M.S. Outlook**

- ❖ **Introduction.**
- ❖ **Opening & Saving Database**
- ❖ **Mail Id Cheeked.**
- ❖ **Documents data to servers to send**
- ❖ **inbox & outbox mail Cheeked. In computer**
- ❖ **Creating & Printing reports.**

#### **Tally**

- ❖ **Introduction about Key Stocks, Students, Version, Faculty.**
- ❖ **Business, Organ lotion, Service organization, trading organization.**
- ❖ **Accounting Principles, Concepts & Convention Definition.**
- ❖ **Type of Concepts.**
- ❖ **Type of Conventions.**
- ❖ **All of Accounting Concepts.**

#### **D.T.P.**

**Coral Draw - 12 versions.**

- ❖ **Introduction.**
- ❖ **Setting up the page.**
- ❖ **Moving around and viewing drawings.**
- ❖ **Customizing option.**
- ❖ **Object Creation and manipulation.**
- ❖ **Working with Special Effects and text**
- ❖ **Page layout, printing, exporting and advanced features.**

#### **PageMaker –7.0 versions.**

- ❖ **Introduction.**
- ❖ **Working with Documents.**
- ❖ **Editing Text Documents.**
- ❖ **Formatting Documents.**
- ❖ **Setting Paragraph style.**
- ❖ **Setting Document styles.**
- ❖ **Setting Documents styles.**
- ❖ **Drawing Tools.**

- ❖ Tools
- ❖ Printing Documents.

### Photoshop – 7.0 versions.

- ❖ Introduction.
- ❖ Drawing and aping objects
- ❖ Photo Editing and Images cutting
- ❖ Selecting & Manipulating Images.
- ❖ Moving around and viewing drawings.
- ❖ Photo Effects Images Change Images
- ❖ Photo Frame Editing & Changes.
- ❖ Drawing Tools.
- ❖ Tools
- ❖ Printing Documents.

### Hardware & Networking

- ❖ Microprocessor.
- ❖ Memory.
- ❖ Mother board.
- ❖ Power supply Coding & Protection.
- ❖ Floppy Disk Drive.
- ❖ Hard Disk Drive.
- ❖ CD Rom & Combo Drives.
- ❖ SCSI Drives.
- ❖ Installing Drives.
- ❖ Antivirus software's.
- ❖ Working with the BIOS/CMOS.
- ❖ PC Maintenance & Troubleshooting.
- ❖ Installing windows-2003
- ❖ Working with Window-2003 Devices & Drives.

Basic Information and working 'C' Languages

Basic Information and HTML Command use

### PRACTICALS:

- ❖ Practical on MS Office, Tally, Coral Draw, Photoshop.



NAME OF THE COURSE	Computer Hardware & Networking
DURATION	1 Year
CAPACITY	10 members
QUALIFICATION	10 <sup>th</sup> Passed

**Topics covered under Computer Hardware & Networking course:**

**THEORY:**

- ❖ Microprocessor.
- ❖ Memory.
- ❖ Mother board.
- ❖ Power supply Coding & Protection.
- ❖ Floppy Disk Drive.
- ❖ Hard Disk Drive.
- ❖ CD Rom & Combo Drives.
- ❖ SCSI Drives.
- ❖ Installing Drives.
- ❖ Installing Antivirus software's.
- ❖ Working with the BIOS/CMOS.
- ❖ PC Maintenance & Troubleshooting.
- ❖ Installing windows server -2003
- ❖ Working with Windows Server -2003 Devices & Drives.
- ❖ Managing System Up data.
- ❖ Working with Window Disk of storages.
- ❖ Configuring DNS.
- ❖ Working with DNS server's properties and TCP/IP.
- ❖ Working DHCP.
- ❖ Integrating DNS with DHCP & DHCP Relay Agent.



**PRACTICALS:**

- ❖ Assembling & disassembling of systems.
- ❖ Installation and configuration of Hardware devices in system.
- ❖ Installation of Local Area Network (LAN)
- ❖ Troubleshooting of System, LAN

<b>NAME OF THE COURSE</b>	<b>Diploma in Computer Application (DCA)</b>
<b>DURATION</b>	<b>1 Year</b>
<b>CAPACITY</b>	<b>10 members</b>
<b>QUALIFICATION</b>	<b>10<sup>th</sup> Passed</b>

## **Topics covered under Diploma in Computer Application (DCA) Course:**

### **THEORY:**

#### **Introduction to Computer and Hardware Networking**

- ❖ Working with Computer's
- ❖ Computer Tools & Utilities.
- ❖ Computer Terminologies
- ❖ Software and Hardware
- ❖ Hardware Accessories
- ❖ Manipulating file & Folders
- ❖ Software Application
- ❖ Working with the windows environments
- ❖ Operating System software
- ❖ Introduction to Internet
- ❖ Types of Networks
- ❖ Internet Architecture
- ❖ Computer Topologies
- ❖ IP, HTTP, WWW,
- ❖ 1Domains, Web pages
- ❖ Email Id, online Transaction
- ❖ Microprocessor.
- ❖ Memory.
- ❖ Mother board.
- ❖ Power supply Coding & Protection.

- ❖ Floppy Disk Drive.
- ❖ Hard Disk Drive.
- ❖ CD Rom & Combo Drives.
- ❖ SCSI Drives.
- ❖ Installing Drives.
- ❖ Antivirus software's.
- ❖ Working with the BIOS/CMOS.
- ❖ PC Maintenance & Troubleshooting.
- ❖ Installing windows-2003
- ❖ Working with Window-2003 Devices & Drives.
- ❖ Managing System Up data.
- ❖ Working with Window Disk of storages

#### **MS Office 2007(Word, Excel, Power Point, Access, Outlook, Publisher, M.S. Word)**

- ❖ Introduction.
- ❖ Working with Documents.
- ❖ Editing Text Documents.
- ❖ Formatting Documents.
- ❖ Setting Paragraph style.
- ❖ Setting Document styles.
- ❖ Setting Documents styles.
- ❖ Drawing Tools.
- ❖ Tools
- ❖ Printing Documents

#### **M.S. Excel**

- ❖ Introduction
- ❖ Working with Documents.
- ❖ Formatting Spreadsheets.
- ❖ Working with Sheets.
- ❖ Working with Sheets.
- ❖ Creating Charts.
- ❖ Using Tools.
- ❖ Computer Entering and Editing data.
- ❖ Sheets. Formatting & Style Background, Colour, Borders, & shading.
- ❖ Printing work Sheets.

## **M.S. Power point**

- ❖ **Introduction.**
- ❖ **Creating a Presentation.**
- ❖ **Formatting a Presentation.**
- ❖ **Adding Graphics to the presentation.**
- ❖ **Adding effects to the presentation.**
- ❖ **Setting presentation styles.**
- ❖ **Inserting Pictures, movies, tables, etc. Into the presentation.**
- ❖ **Opening New Presentation.**
- ❖ **Printing Handouts.**
- ❖ **Generating Standalone Presentation viewer.**

## **M.S. Access**

- ❖ **Introduction.**
- ❖ **Opening & Saving Database Files**
- ❖ **Creating Queries.**
- ❖ **Creating Forms**
- ❖ **Creating & Printing reports.**

## **M.S.Outlook**

- ❖ **Introduction.**
- ❖ **Opening & Saving Database**
- ❖ **Mail Id Cheeked.**
- ❖ **Documents data to servers to send**
- ❖ **Inbox & outbox mail Cheeked. In computer**
- ❖ **Creating & Printing reports.**

## **Tally 9.0:**

- ❖ **Introduction about Key Stocks, Students, Version, Faculty.**
- ❖ **Business, Organ lotion, Service organisation, trading organisation.**
- ❖ **Accounting Principles, Concepts & Convention Definition.**
- ❖ **Type of Concepts.**
- ❖ **Type of Conventions.**
- ❖ **All of Accounting Concepts**

## **Desktop Publication (DTP)**

### **Coral Draw - 12 versions.**

- ❖ **Introduction.**

- ❖ **Setting up the page.**
- ❖ **Moving around and viewing drawings.**
- ❖ **Customizing option.**
- ❖ **Object Creation and manipulation.**
- ❖ **Working with Special Effects and text**
- ❖ **Page layout, printing, exporting and advanced features**

#### **PageMaker – 7.0 versions**

- ❖ **Introduction.**
- ❖ **Working with Documents.**
- ❖ **Editing Text Documents.**
- ❖ **Formatting Documents.**
- ❖ **Setting Paragraph style.**
- ❖ **Setting Document styles.**
- ❖ **Setting Documents styles.**
- ❖ **Drawing Tools.**
- ❖ **Tools**
- ❖ **Printing Documents**

#### **Photoshop – 7.0 versions**

- ❖ **Introduction.**
- ❖ **Drawing and aping objects**
- ❖ **Photo Editing and Images cutting**
- ❖ **Selecting & Manipulating Images.**
- ❖ **Moving around and viewing drawings.**
- ❖ **Photo Effects Images Change Images**
- ❖ **Photo Frame Editing & Changes.**
- ❖ **Drawing Tools.**
- ❖ **Tools**
- ❖ **Printing Documents.**



#### **PRACTICALS:**

**Practical on MS-Office, Tally, Photoshop regularly.**

<b>NAME OF THE COURSE</b>	<b>MS-Office with Internet</b>
<b>DURATION</b>	<b>2 Months</b>
<b>CAPACITY</b>	<b>5 members</b>
<b>QUALIFICATION</b>	<b>10<sup>th</sup> Passed</b>

## **Topics covered under MS-Office with Internet Course:**

### **THEORY:**

#### **MS Office 2007(Word, Excel, Power Point, Access, Outlook, Publisher, M.S. Word)**

- ❖ Introduction.
- ❖ Working with Documents.
- ❖ Editing Text Documents.
- ❖ Formatting Documents.
- ❖ Setting Paragraph style.
- ❖ Setting Document styles.
- ❖ Setting Documents styles.
- ❖ Drawing Tools.
- ❖ Tools
- ❖ Printing Documents



#### **M.S. Excel**

- ❖ Introduction
- ❖ Working with Documents.
- ❖ Formatting Spreadsheets.
- ❖ Working with Sheets.
- ❖ Working with Sheets.
- ❖ Creating Charts.
- ❖ Using Tools.
- ❖ Computer Entering and Editing data.
- ❖ Sheets. Formatting & Style Background, Colour, Borders, & shading.

- ❖ **Printing work Sheets.**

### **M.S. Power point**

- ❖ **Introduction.**
- ❖ **Creating a Presentation.**
- ❖ **Formatting a Presentation.**
- ❖ **Adding Graphics to the presentation.**
- ❖ **Adding effects to the presentation.**
- ❖ **Setting presentation styles.**
- ❖ **Inserting Pictures, movies, tables, etc. Into the presentation.**
- ❖ **Opening New Presentation.**
- ❖ **Printing Handouts.**
- ❖ **Generating Standalone Presentation viewer.**

### **M.S. Access**

- ❖ **Introduction.**
- ❖ **Opening & Saving Database Files**
- ❖ **Creating Queries.**
- ❖ **Creating Forms**
- ❖ **Creating & Printing reports.**

### **M.S.Outlook**

- ❖ **Introduction.**
- ❖ **Opening & Saving Database**
- ❖ **Mail Id Cheeked.**
- ❖ **Documents data to servers to send**
- ❖ **Inbox & outbox mail Cheeked. In computer**
- ❖ **Creating & Printing reports.**

### **Internet**

- ❖ **Introduction of Internet**
- ❖ **LAN, WAN, MAN**
- ❖ **Browsers, Http,**
- ❖ **E-mail, Configuration**

### **PRACTICALS:**

- ❖ **Practical on MS-Office,**

<b>NAME OF THE COURSE</b>	<b>Accountancy with Tally</b>
<b>DURATION</b>	<b>2 Months</b>
<b>CAPACITY</b>	<b>5 members</b>
<b>QUALIFICATION</b>	<b>10<sup>th</sup> Passed</b>

## **Topics covered under Accountancy with Tally Course:**

### **THEORY:**

- ❖ Introduction about Key Stocks, Students, Version, Faculty.
- ❖ Business, Organ lotion, Service organisation, trading organisation.
- ❖ Accounting Principles, Concepts & Convention Definition.
- ❖ Type of Concepts.
- ❖ Type of Conventions.
- ❖ All of Accounting Concepts.

### **PRACTICALS:**

**Practical on Tally Software.**



<b>NAME OF THE COURSE</b>	<b>PC Maintenance</b>
<b>DURATION</b>	<b>6 Months</b>
<b>CAPACITY</b>	<b>5 members</b>
<b>QUALIFICATION</b>	<b>10<sup>th</sup> Passed</b>

**Topics covered under PC Maintenance Course:**

**THEORY:**

- ❖ **Microprocessor.**
- ❖ **Memory.**
- ❖ **Mother board.**
- ❖ **Power supply Coding & Protection.**
- ❖ **Floppy Disk Drive.**
- ❖ **Hard Disk Drive.**
- ❖ **CD Rom & Combo Drives.**
- ❖ **SCSI Drives.**
- ❖ **Installing Drives.**
- ❖ **Installing Antivirus software's.**
- ❖ **Working with the BIOS/CMOS.**
- ❖ **PC Maintenance & Troubleshooting.**
- ❖ **Installing windows server -2003**

**PRACTICALS:**

- ❖ **Assembling & disassembling of systems.**
- ❖ **Installation and configuration of Hardware devices in systems.**
- ❖ **Installation of Local Area Network (LAN)**

<b>NAME OF THE COURSE</b>	<b>Course on Computer Concept (CCC)</b>
<b>DURATION</b>	<b>2 Months</b>
<b>CAPACITY</b>	<b>5 members</b>
<b>QUALIFICATION</b>	<b>10<sup>th</sup> Passed</b>

## **Topics covered under Course on Computer Concept (CCC) Course:**

### **THEORY:**

#### **❖ INTRODUCTION TO COMPUTER**

- Objectives
- Objectives
- What is Computer?
- Components of Computer System
- Concept of Hardware and Software
- Representation of Data/Information
- Concept of Data processing
- Applications of IECT
- Summary
- Model Questions and Answers



#### **❖ INTRODUCTION TO GUT BASED OPERATING SYSTEM**

- Introduction
- Objectives
- Basics of Operating System
- The User Interface
- Operating System Simple Setting
- File and Directory Management
- Types of files
- Summary
- Model Questions and Answers

#### **❖ ELEMENTS OF WORD PROCESSING**

- Introduction
- Objectives
- Word Processing Basics
- Opening and closing Documents
- Text Creation and manipulation

- Formatting the text
- Table Manipulation
- Summary
- Model Questions and Answers

#### ❖ **SPRED SHEET**

- Introduction
- Objectives
- Elements of Electronic Spread Sheet
- Manipulation of Cells
- Function and charts
- Summary
- Model Questions and Answers

#### ❖ **COMPUTER COMMUNICATION AND INTERNET**

- Introduction
- Objectives
- Basics of Computer Networks
- Internet
- Services on Internet
- Preparing Computer for Internet Access
- Summary
- Model Questions and Answers

#### ❖ **WWW AND WEB BROWSER**

- Introduction
- Objectives
- Web Browser
- Configuring Web Brower
- Search Engines
- Summary
- Model Questions and Answers

#### ❖ **COMMUNICATION AND COLLABORATION**

- Introduction
- Objectives
- Basics of E-mail
- Using E-mails

#### ❖ 4 Advance email features

#### ❖ 7.5 Instant Messaging and Collaboration

#### ❖ 7.6 Summary

#### ❖ 7.7 Model Questions and Answers

#### **PRACTICALS:**

#### ❖ **Practical on MS-Office and Computer systems**

<b>NAME OF THE COURSE</b>	<b>Auto CAD (Mechanical)</b>
<b>DURATION</b>	<b>2 Months</b>
<b>CAPACITY</b>	<b>20 members</b>
<b>QUALIFICATION</b>	<b>10<sup>th</sup> Passed</b>

### **Topics covered under Auto (Mechanical) Course:**

#### **THEORY:**

- ❖ Basics of computer and CAD.
- ❖ How to make 2D drawings in Auto CAD.
- ❖ How to make 3D models in Auto CAD.
- ❖ How to edit and modify drawings in Auto CAD.
- ❖ Hatching utilities create and edit.
- ❖ Advanced objects creations and editing.
- ❖ How to dimensions entities.
- ❖ How to create and assess symbols.
- ❖ How to prepare and manage a layout.
- ❖ How to print drawings and 3D models.

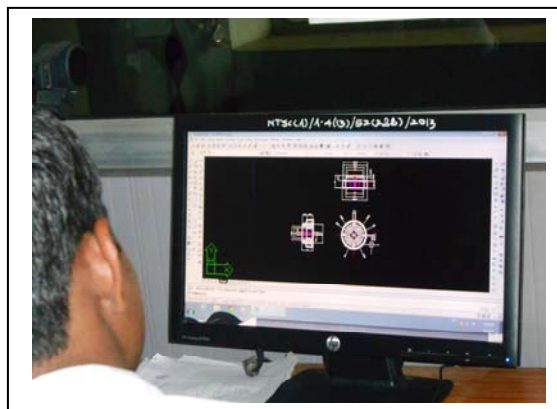

<b>NAME OF THE COURSE</b>	<b>Diploma in product Design Engg.</b>
<b>DURATION</b>	<b>1 Year</b>
<b>CAPACITY</b>	<b>10 members</b>
<b>QUALIFICATION</b>	<b>10<sup>th</sup> Passed (Science)</b>

## Topics covered under Diploma in product Design Engineering Course:

### THEORY:

- ❖ Introduction about Engg Drawings.
- ❖ Lines and types
- ❖ Symbols
- ❖ Lettering
- ❖ Projection
- ❖ 1st Angle & 3rd Angle
- ❖ Isometric views
- ❖ Orthographic view
- ❖ Dimension Techniques
- ❖ Open Assembly Drawing
- ❖ Computer Awareness
- ❖ Auto CAD Basics
- ❖ Awareness of CAD/CAM n DELCAM
- ❖ Introduction to Tool Design
- ❖ Awareness with Tool Room m/c & Safety
- ❖ Designing Concept & Design parameters
- ❖ Press Tool Design
- ❖ Material selection
- ❖ Limits, Fits Tolerances
- ❖ Explain about measurement
- ❖ Awareness of measuring instruments

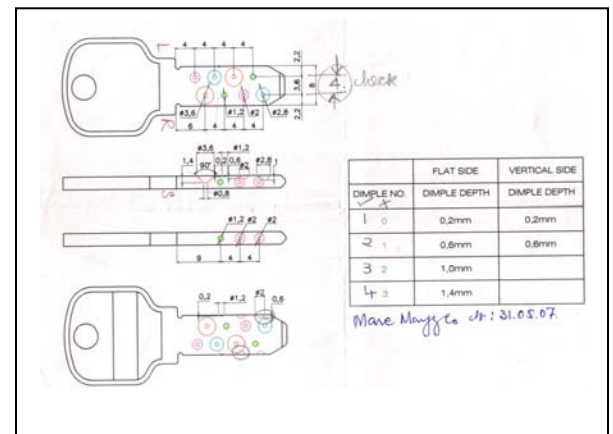

- ❖ Awareness of measuring instruments.
- ❖ Machining process
- ❖ Product design practices
- ❖ Awareness with jigs & Fixtures
- ❖ Inspection & quality improvement techniques.
- ❖ Re – Engineering through 3D Digitizer (Micro Scriber)
- ❖ Project work

## Master CAM

- ❖ Creating 2D Geometry
- ❖ Solid Modeling
- ❖ Configuring Master cam
- ❖ Creating 3D Geometry
- ❖ Dimensioning
- ❖ Applying Tool paths; Contour, Pocketing, Drilling and tapping
- ❖ Back plot, Verification and stl Compare
- ❖ Work Coordinate System (WCS) and working on Multiple Sides of a Part.
- ❖ Use the mill module of the Master CAM software to convert the modeled part geometry into a cutter tool path for use on a numerically controlled milling machine.
- ❖ Use the lathe module of the Master CAM software to convert the modeled part geometry into a cutter tool path for use on a numerically controlled lathe.
- ❖ Safely operate the laboratory CNC machinery to mill a part model from wood, plastic or metal material.

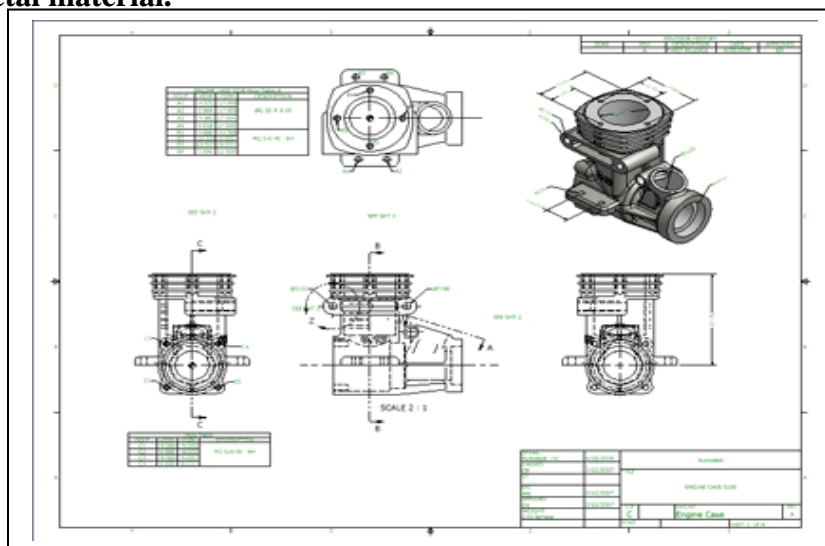
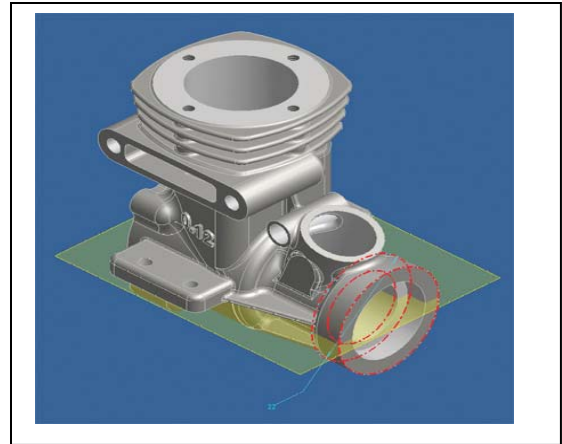

<b>NAME OF THE COURSE</b>	<b>Advance Course in CAD/CAM</b>
<b>DURATION</b>	<b>6 Months</b>
<b>CAPACITY</b>	<b>10 members</b>
<b>QUALIFICATION</b>	<b>Dip./ BE</b>

## Topics covered under Advance Course in CAD/CAM Course:

### THEORY:

- ❖ Introduction to the Trade
- ❖ AutoCAD: 2D, 3D & modeling
- ❖ Convectional machine : lathe, milling
- ❖ EDM, Drilling, Grinding, Shaper etc.
- ❖ DELCAM : Power shape (Design)and Power Mill
- ❖ Fits, Limits & Tolerances
- ❖ CNC : programming & Operation on CNC Lathe,
- ❖ Milling, wire cut
- ❖ CAM: Practical on NX tooling and Master CAM
- ❖ Software, Tool Design : Design : Designing of Press
- ❖ Tools, Dies, Moulds
- ❖ Low Cost Automation : Application of Hydraulics,
- ❖ Pneumatics, Electronics devices & Other Indigenize
- ❖ Ideas
- ❖ Reverse Engineering : Concept and practice on
- ❖ 3D-Digitizer
- ❖ Project Work



## Introduction:

Computer-aided technologies (CAx) is a broad term that means the use of computer technology to aid in the design, analysis, and manufacture of products.

Advanced CAx tools merge many different aspects of the product lifecycle management (PLM), including design, finite element analysis (FEA), manufacturing, production planning, product Computer-aided design (CAD)

- Computer-aided engineering (CAE) Computer-aided industrial design (CAID)
- Computer-aided manufacturing (CAM)
- Computer-aided requirements capture (CAR)
- Computer-aided rule definition (CARD)
- Computer-aided rule execution (CARE)
- Computer-aided software engineering (CASE)
- Computational fluid dynamics (CFD)
- Component information system (CIS)
- Computer-integrated manufacturing (CIM)
- computer numerical controlled (CNC)
- Electronic design automation (EDA)

## Application of CAD/CAM

- Aerospace
- • Automotive
- • Chemical & Process
- • Communications
- • Computers & IT
- • Electrical & Electronics Examples
- • Medical & Pharma
- • Military & Defence
- • Rail & Marine
- • Structural & Civil
- • Apparel and Textile

## PRACTICALS:

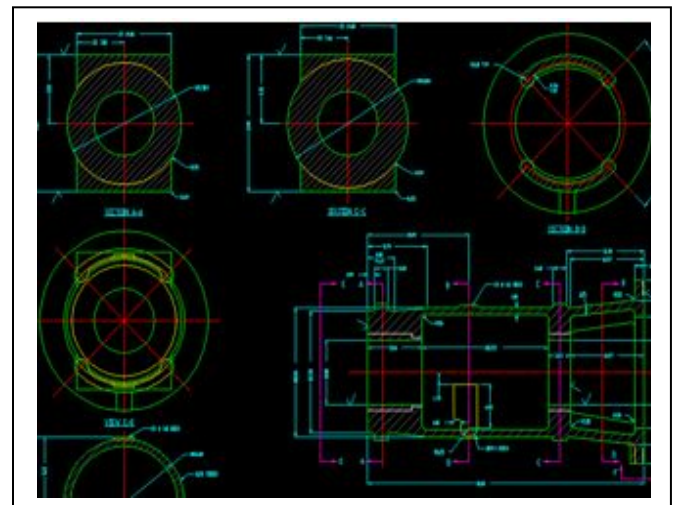
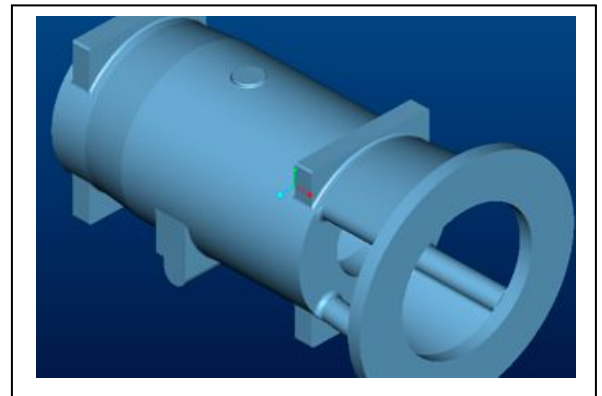

<b>NAME OF THE COURSE</b>	<b>Certificate Course in CAD/CAM (Computer Aided Design and Computer Aided Manufacturing)</b>
<b>DURATION</b>	<b>1 Year</b>
<b>CAPACITY</b>	<b>20 members</b>
<b>QUALIFICATION</b>	<b>10+2 Passed (Science)</b>

### **Topics covered under Certificate Course in CAD/CAM Course:**

#### **THEORY:**

- ❖ Trade Introduction
- ❖ Computer Awareness
- ❖ Engg. Drawing : Practices
- ❖ Auto CAD : 2D , 3D & Modeling
- ❖ Hard Tools & Cutting Tools
- ❖ Conventional Machines : Lathe , Milling
- ❖ EDM, Drilling , Grinding, Shaper etc.
- ❖ DELCAM : Power shape ( Design ) and power Mill
- ❖ Fits, Limits & Tolerances
- ❖ CNC : Programming & Operation on CNC Lathe,
- ❖ VMC/CNC Milling, CNC wire cut
- ❖ CAM : Practical on NX Tooling and Master CAM Software
- ❖ Tool Design : Designing of Press tools, Plastic Zinc & Aluminum Die Casting dies, jigs & Fixtures
- ❖ Low Cost Automation : Application of Hydraulics, Pneumatics, Electronics devices & other Indigenizing ideas
- ❖ Metrology : Measurement & proper use measuring instruments
- ❖ Reverse Engineering : Concept and practices on 3D- Digitizer
- ❖ Project Work



<b>NAME OF THE COURSE</b>	<b>Advance Course in Die &amp; Mould Manufacturing</b>
<b>DURATION</b>	<b>1 Year</b>
<b>CAPACITY</b>	<b>10 members</b>
<b>QUALIFICATION</b>	<b>10+2 Passed (Science)/ITI</b>

## Topics covered under Certificate Course in CAD/CAM Course:

### THEORY:

- ❖ Introduction
- ❖ Industrial Safety and precaution.
- ❖ Hand tools.
- ❖ Filing work.
- ❖ Bench vices and machine vices.
- ❖ Metals –Ferrous and Non-Ferrous, Selection of metals.
- ❖ Engineering Drawings.
- ❖ Workshop calculation.
- ❖ Measurement and measuring instruments.
- ❖ Trends in machine tools.
- ❖ Shaper machine and shaping operations.
- ❖ Milling machine and milling operations.
- ❖ Milling accessories and attachments.
- ❖ Types of milling cutters & SELECTION OF CUTTERS
- ❖ Grinding operations and type of grinding m/c
- ❖ Selection of Grinding wheels.
- ❖ Familiarization about tools & Dies, Moulds.



- ❖ Press tools-Blanking, Piercing, Bending and Forming
- ❖ Dies for pressure Die Casting.
- ❖ Zinc Die Casting.
- ❖ Forging Dies.
- ❖ Dies & Tools Manufacturing Process.
- ❖ Assembly Practices.
- ❖ Test & trial of dies and moulds.
- ❖ Industrial Visit.
- ❖ Introduction to CNC Lathe M/c.
- ❖ Revision of Engg Drawings.
- ❖ Co-ordinate Geometry.
- ❖ Computer awareness.
- ❖ Introduction to CNC-System.
- ❖ Advantage of CNC.
- ❖ Introduction to programming method.
- ❖ Types of Programming.
- ❖ Programming of 'G' Codes.
- ❖ Programming of other additional Codes.
- ❖ Details of Button of control unit.
- ❖ Setting of the Job on Machine.
- ❖ Setting of tool for reference.
- ❖ Program Transfer M/c to PC and PC to M/c.
- ❖ Practice on Exercise Programming as well as Machining.
- ❖ Heat treatment Awareness.
- ❖ Jigs, Fixtures and gauges, Limits, Fits and Tolerances.
- ❖ Manufacturing process and production Management.
- ❖ Inspection & quantity improvement techniques.
- ❖ Project work.



<b>NAME OF THE COURSE</b>	<b>Master-CAM</b>
<b>DURATION</b>	<b>2 Months</b>
<b>CAPACITY</b>	<b>5 members</b>
<b>QUALIFICATION</b>	<b>ITI/Dip./B.Tech./BE</b>

## **Topics covered under Master-CAM Course:**

### **THEORY:**

- ❖ **Creating 2D Geometry**
- ❖ **Solid Modeling**
- ❖ **Configuring Master cam**
- ❖ **Creating 3D Geometry**
- ❖ **Dimensioning**
- ❖ **Applying Tool paths, Contour, Pocketing, Drilling and tapping**
- ❖ **Back plot, Verification and stl Compare**
- ❖ **Work Coordinate System (WCS) and working on Multiple Sides of a Part.**
- ❖ **Use the mill module of the Master-CAM software to convert the modeled part geometry into a cutter tool path for use on a numerically controlled milling machine.**
- ❖ **Use the lathe module of the Master-CAM software to convert the modeled part geometry into a cutter tool path for use on a numerically controlled lathe.**
- ❖ **Safely operate the laboratory CNC machinery to mill a part model from wood, plastic or metal material.**

### **PRACTICALS:**

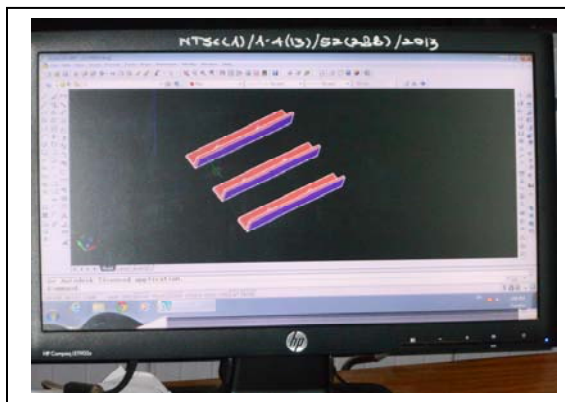

<b>NAME OF THE COURSE</b>	<b>NX Tooling</b>
<b>DURATION</b>	<b>2 Months</b>
<b>CAPACITY</b>	<b>5 members</b>
<b>QUALIFICATION</b>	<b>ITI/Dip./B. Tech./BE</b>

**Topics covered under NX Tooling Course:**

**THEORY:**

- ❖ **Configure software and licenses for running NX**
- ❖ **Manufacturing Objects (The operation navigation views).Install training related and demo file.**
- ❖ **Demonstration overview**
- ❖ **Cavity Milling and drilling techniques**
- ❖ **Cavity Milling and drilling techniques**
- ❖ **Planar Milling Introduction to Profiling**
- ❖ **Fixed axis contouring**
- ❖ **Post processing**
- ❖ **Multi-Axis Basics Fundamentals showing**
- ❖ **4 and 5 axis functionality Machining Tool axis**

**PRACTICALS:**

<b>NAME OF THE COURSE</b>	<b>Pro-Engineer (Latest Version)</b>
<b>DURATION</b>	<b>2 Months</b>
<b>CAPACITY</b>	<b>5 members</b>
<b>QUALIFICATION</b>	<b>ITI /Dip./ B.Tech. /BE</b>

**Topics covered under Pro-Engineer Course:**

**THEORY:**

**Introduction**

- ❖ Introduction to CAD/CAM /CAE
- ❖ Parametric Design, Associative, Feature Based Modeling
- ❖ System Requirements
- ❖ Graphic User Interface of Pro/E
- ❖ Getting Started With Pro Engineering
- ❖ File Operations

**Sketcher**

- ❖ Creation Tools
- ❖ Dimensioning & Constraints
- ❖ Sketcher Palette
- ❖ Sketcher Relations

**Part Modeling**

- ❖ Getting started With Part Modeling
- ❖ Creation of Features
- ❖ Datum Tools
- ❖ View Manager
- ❖ Engineering Features
- ❖ Edit Features
- ❖ Advanced Feature Operations
- ❖ Pattern
- ❖ Advanced Utilities

❖ **Model Analysis**

**Introduction to Surface Modeling**

❖ **Basic Surfacing Tools**

❖ **Use of Datum Sketcher**

❖ **Variable Section Sweep**

❖ **Boundary Blend**

**Assembly Mode**

❖ **Getting Started With Assembly**

❖ **Bottom-up Approach**

❖ **Assembly Features**

❖ **Top-down Approach**

❖ **Interference & Clearance Checks**

❖ **Exploded Views**

❖ **Advanced Utilities**

**Drafting**

❖ **Overview of Drafting**

❖ **Creating Drawing Views**

❖ **Insert Templates, Format**

❖ **Show & Erase Tool,**

❖ **Creation of Dimensions**

❖ **Symbol Creations & Placements**

❖ **Bill of Materials**

❖ **Drawing Tools**

❖ **GD & T**

**Introduction to Sheet metal**

**Introduction to PRO- Mechanism**

**Tips & Tricks**

❖ **File Management**

❖ **Export and Import of CAD Files**

❖ **Concept of Version Files**

❖ **Managing PRO-E Environment**

<b>NAME OF THE COURSE</b>	<b>Advance Training course in Electrician</b>
<b>DURATION</b>	<b>6 Months</b>
<b>CAPACITY</b>	<b>5 members</b>
<b>QUALIFICATION</b>	<b>ITI</b>

**Topics covered under Advance Training course in Electrician:**

**THEORY:**

- ❖ Introduction
- ❖ Industrial Safety and Precaution.
- ❖ Sign and Symbol.
- ❖ Basic Electric-Definition of Voltage, Current,
- ❖ EMF & Resistance.
- ❖ Ohm's law, Work, Energy and Power.
- ❖ Resistance law-Series & parallel connections
- ❖ Conductors and Non-Conductors
- ❖ Capacitor and Inductor
- ❖ Electrolysis
- ❖ Magnet and Electro-magnet
- ❖ A.C Circuit, Lagging & Leading power factor.
- ❖ A.C Power, disadvantages of low power factor.
- ❖ Alternator, Transformer, Regulation, Efficiency
- ❖ Single phase and three phase motors.
- ❖ Capacitor Motor (Theory and Practical)
- ❖ Repulsion Motor (Theory and practical)
- ❖ Universal motor (Theory and practical)
- ❖ Three phase Motors (Theory and practical)



**PRACTICALS:**

<b>NAME OF THE COURSE</b>	<b>Advance Training course in Turner</b>
<b>DURATION</b>	<b>6 Months</b>
<b>CAPACITY</b>	<b>5 members</b>
<b>QUALIFICATION</b>	<b>ITI</b>

**Topics covered under Advance Training course in Turner:**

**THEORY**

- ❖ Introduction
- ❖ Workshop calculation.
- ❖ Measurement and measuring instruments.
- ❖ Trends in machine tools
- ❖ Lathe machine and its parts.
- ❖ Lathe machine operations.
- ❖ Lathe accessories and attachments.
- ❖ Types of lathes.
- ❖ Single Point Cutting Tools and Multi Cutters.
- ❖ Selection of drills and taps for Threading.
- ❖ Types of threads.
- ❖ Practices.



<b>NAME OF THE COURSE</b>	<b>Advance Training course in Machinist</b>
<b>DURATION</b>	<b>6 Months</b>
<b>CAPACITY</b>	<b>5 members</b>
<b>QUALIFICATION</b>	<b>ITI</b>

**Topics covered under Advance Training course in Machinist:**

**THEORY**

- ❖ Introduction
- ❖ Filing work
- ❖ Bench vices and machine vices
- ❖ Metals-Ferrous and Non- Ferrous, Selection of metals
- ❖ Engineering Drawings
- ❖ Workshop calculation
- ❖ Measurement and measuring instruments
- ❖ Trends in machine tools
- ❖ Shaper machine and shaping operations
- ❖ Milling machine and Milling operations
- ❖ Type of milling cutters & selection of cutters
- ❖ Grinding operations and type of grinding m/c
- ❖ Selection of Grinding wheels
- ❖ Awareness about CNC and EDM machines



<b>NAME OF THE COURSE</b>	<b>Advance Training course in Fitter</b>
<b>DURATION</b>	<b>6 Months</b>
<b>CAPACITY</b>	<b>5 members</b>
<b>QUALIFICATION</b>	<b>ITI</b>

**Topics covered under Advance Training course in Fitter:**

**THEORY**

- ❖ Introduction to Fitter
- ❖ Measurement and measuring
- ❖ Limits, Fits, tolerances
- ❖ Trends in machine tools
- ❖ Drilling Operations and Radial Drill machine.
- ❖ Shaper machine and shaping operations.
- ❖ Milling machine and Milling operations.
- ❖ Milling accessories and attachments.
- ❖ Types of milling cutters & selection of cutters.
- ❖ Grinding operations and type of Dies, Moulds.
- ❖ Selection of Grinding wheels.
- ❖ Familiarization about tools & Dies, Moulds.
- ❖ Press Tools-Blanking Piercing, Bending & Forming.
- ❖ Dies and Tools Manufacturing Process.
- ❖ Jigs, Fixtures & gauges.
- ❖ Production Management.
- ❖ Assembly Practices.

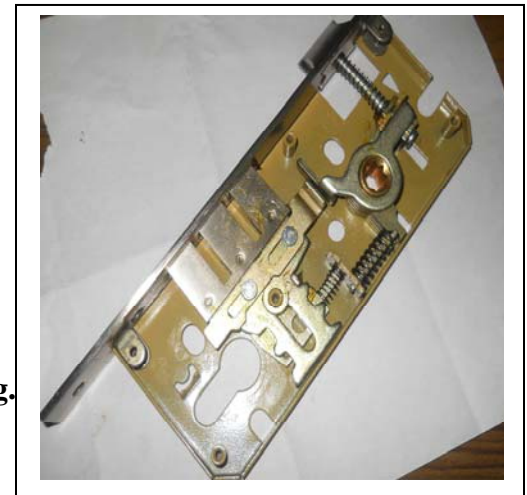

<b>NAME OF THE COURSE</b>	<b>Advance Training course in Tool &amp; Die Maker</b>
<b>DURATION</b>	<b>6 Months</b>
<b>CAPACITY</b>	<b>5 members</b>
<b>QUALIFICATION</b>	<b>ITI</b>

**Topics covered under Tool & Die Maker:**

**THEORY**

- ❖ Introduction
- ❖ Drilling and Types of Drill Machine
- ❖ Milling machine and its operations
- ❖ Lathe and lathe operations Press Tools.
- ❖ Fits, Limits, Tolerances
- ❖ Familiarization about tools & Dies
- ❖ Press Tools-Banking, piercing, Bending & Forming
- ❖ Knowledge of Material
- ❖ Dies for Pressure Die Casting
- ❖ Zinc Die Casting
- ❖ Forging Dies
- ❖ Dies and Tools Manufacturing Process.
- ❖ Assembly Practices.
- ❖ Inspection & Quality Control
- ❖ Test and Trial



<b>NAME OF THE COURSE</b>	<b>Advance Training course in Draughtsman (Mechanical)</b>
<b>DURATION</b>	<b>6 Months</b>
<b>CAPACITY</b>	<b>5 members</b>
<b>QUALIFICATION</b>	<b>ITI</b>

**Topics covered under Draughtsman (Mechanical):**

**THEORY**

- ❖ Introduction to Draughtsman
- ❖ Projection
- ❖ 1th Angle & 3th Angle
- ❖ Isomeric views
- ❖ Orthographic Views .
- ❖ Dimension Techniques
- ❖ Assembly Drawings
- ❖ Work shop calculation
- ❖ Introduction to Tool Design
- ❖ Awareness with Tool room m/c & Safety
- ❖ Designing concept & design parameters
- ❖ Press Tool Design
- ❖ Material selection
- ❖ Limits, Fits, Tolerances
- ❖ Explain about measurement

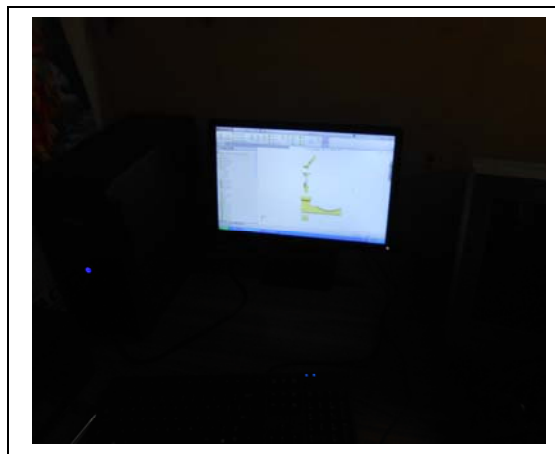

<b>NAME OF THE COURSE</b>	<b>Welding &amp; Fabrications</b>
<b>DURATION</b>	<b>6 Months</b>
<b>CAPACITY</b>	<b>10 members</b>
<b>QUALIFICATION</b>	<b>8<sup>th</sup> Passed</b>

**Topics covered under Welding & Fabrications.**

**THEORY**

- ❖ Introduction to Welding
- ❖ Introduction to safety equipments used in structural welding
- ❖ Familiarization with machinery in shop, Electric cutting.
- ❖ Position welding for making a job by using SMAW 1F, 2F, 3F, 4F
- ❖ Setting gas cutting plant and SMAW weld equipment
- ❖ Structural fitting with tack weld, 3F, 4F position weld
- ❖ Pressure pipe welding and joint by SMAW 5 F position and flange joints, M.S. pipe joint
- ❖ Root pass welding and preparation of different types of joints Cover pass welding (2G, 3G)
- ❖ Setting of TIG welding machine and equipment as per job, working in down position.
- ❖ Making of simple structure with angles, channels, I & T section, correction of distortion, preparation of WPS and PQR welding inspection and test



<b>NAME OF THE COURSE</b>	<b>Refrigeration &amp; Air Conditioning</b>
<b>DURATION</b>	<b>6 Months</b>
<b>CAPACITY</b>	<b>10 members</b>
<b>QUALIFICATION</b>	<b>8<sup>th</sup> Passed</b>

## **Topics covered under Refrigeration & Air Conditioning.**

### **THEORY**

- ❖ Introduction to refrigeration system
- ❖ Refrigeration and A.C. system
- ❖ Compressor
- ❖ Liquid receiver
- ❖ Refrigeration control device
- ❖ Condenser
- ❖ Refrigerants
- ❖ Evaporators
- ❖ Motor control
- ❖ Basic electricity
- ❖ Safety precautions & serviced tools
- ❖ Refrigeration raw material
- ❖ Servicing of machines
- ❖ Science related to refrigeration
- ❖ Refrigeration and A.C. terms
- ❖ Experiments - gas charging, leakage checking, changing of A.C. & refrigerator parts, changing of electric parts, knowing about A.C. & refrigerator problems.



<b>NAME OF THE COURSE</b>	<b>Certificate Course in Fashion Designing</b>
<b>DURATION</b>	<b>12 Months</b>
<b>CAPACITY</b>	<b>10 members</b>
<b>QUALIFICATION</b>	<b>10<sup>th</sup> Passed</b>

**Topics covered under Certificate Course in Fashion Designing:**

**THEORY:**

- ❖ Introduction to the Trade
- ❖ Classification of fabric
- ❖ Fashion Designers national & International
- ❖ Draping Type Draping on Fashion Figures
- ❖ Principles of Design-harmony Rhythm
- ❖ Proportion and Scale , balance emphasis.
- ❖ Sketching-fashion figures (human figures) proportions
- ❖ Fashion Drawing-Basic Shapes, Figures Drawing
- ❖ Stylized figures, fabric rendering, flat Sketching
- ❖ Accessory drawing, fold & Gathers, Shirring etc
- ❖ Materials used in Shading.
- ❖ Computer : Practice of Corel Draw Tools
- ❖ Drawing & Shaping Object
- ❖ Aligning & Editing Objects Data
- ❖ Working with multiple color Palettes
- ❖ Importing & Exporting
- ❖ Printing

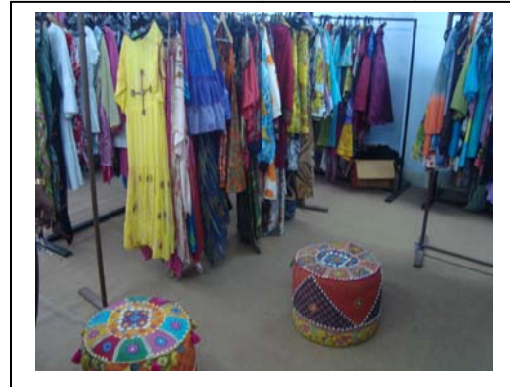

**Practical:**

**Draping Fashion Figures, Ties & Dye Textures & paints, Pencil Techniques & Shading  
Optical Illusion, Batik Painting, Rendering, Oil Painting, garment construction,  
Embroidery, Block Printing**

<b>NAME OF THE COURSE</b>	<b>Fashion Garment</b>
<b>DURATION</b>	<b>6 Months</b>
<b>CAPACITY</b>	<b>5 members</b>
<b>QUALIFICATION</b>	<b>10<sup>th</sup> Passed</b>

## Topics covered under Certificate Course in Fashion Garment:

### THEORY:

- ❖ Introduction to the Trade
- ❖ Classification of fabric
- ❖ Fashion Designers national & International
- ❖ Draping Type Draping on Fashion Figures
- ❖ Principles of Design-harmony Rhythm
- ❖ Proportion a b d Scale, balance emphasis.
- ❖ Sketching-fashion figures (human figures)proportions
- ❖ Fashion Drawing-Basic Shapes, Figures Drawing
- ❖ Stylized figures, fabric rendering, flat Sketching
- ❖ Kids Apparel, New born essentials
- ❖ Cloth Diapers, Simple baby suit
- ❖ Kids wear ,Night Suit
- ❖ Sun – frock
- ❖ A-Shape Frocks
- ❖ School Uniform (Skirt and Blouse)
- ❖ Girls and Women Apparels
- ❖ Peticcoat
- ❖ 4 kali Peticcoat
- ❖ Plated Peticcoat



<b>NAME OF THE COURSE</b>	<b>Tailoring and Embroidery</b>
<b>DURATION</b>	<b>6 Months</b>
<b>CAPACITY</b>	<b>5 members</b>
<b>QUALIFICATION</b>	<b>10<sup>th</sup> Passed</b>

**Topics covered under Certificate Course in Tailoring and Embroidery:**

**THEORY:**

- ❖ Introduction to Sewing
- ❖ Information on Sewing Machines
- ❖ Maintenance of Sewing Machines
- ❖ Repairs and corrections in Machine and stitches
- ❖ Useful materials for sewing
- ❖ Techniques
- ❖ Information on body structure
- ❖ Right technique for measurements
- ❖ Precaution while cutting
- ❖ Useful tip for perfect sewing
- ❖ Embroidery tools & equipment.
- ❖ Categories of basic stitches of hand embroidery-their techniques and applications.
- ❖ Embroidery threads and their classification.
- ❖ Selection of threads & needles according to the texture and fiber of the material.
- ❖ Tracing technique.
- ❖ Tracing methods.
- ❖ Ironing & finishing of the embroidered articles.
- ❖ Identification of fiber and their characteristics.
- ❖ Shade work, its kinds, techniques & characteristics.
- ❖ Girls and Women Apparels, Peticcoat
- ❖ 4 kali Peticcoat
- ❖ Plated Peticcoat



<b>NAME OF THE COURSE</b>	<b>TQM/ISO 9001:2008 Awareness</b>
<b>DURATION</b>	<b>One week</b>
<b>CAPACITY</b>	<b>5 members</b>
<b>QUALIFICATION</b>	<b>Dip. Engg./B.Tech/MBA</b>

### Topics covered under TQM/ISO 9001:2008-

#### THEORY:

- ❖ Introduction.
- ❖ Industrial Safety and Precautions.
- ❖ Definitions and Vocabulary.
- ❖ Overview to ISO 9001 /QS 9000.
- ❖ Scope.
- ❖ Quality management System (QMS).
- ❖ Resource management.
- ❖ Product Realization.
- ❖ Measurement, Analysis and Improvement.
- ❖ Internal Audit & Auditor's Role.
- ❖ Statistical Techniques for Quality Control.

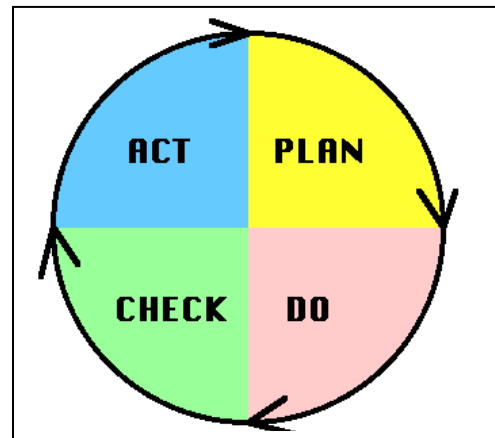

1. Designing & Developing of Tools, Dies & Moulds.
2. Designing & Developing of Jigs-Fixture & Gauges.
3. Common Facility Services are Provided to Lock & Hardware Industries.
4. The centre is having General Purpose as well as High-Tech Machines & a Team of Qualified Engineers & Technicians.
5. The machines installed as under :  
 Precision Lathe, Milling Machines, Cylindrical & Surface Grinders, Shaper, Power Press, CNC Lathe, Key-Dimpling Machine, Key Biting, Key Sloting, Pin Hole drilling Machine, Barrel Broaching Machine, EDM & CNC Wire Cut, & CNC Milling / VMC & Profile Projector etc.
6. The Supporting Activities of the Centre are Heat Treatment, Hardness Tester and Design Facilities.

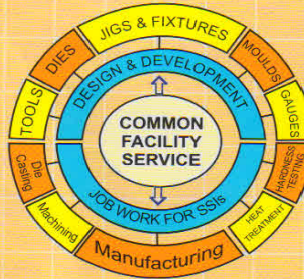

**NSIC, Aligarh कैसे पहुँचें**

